	文件名称	单玻光伏组件安装说明书		
	文件编号	HTL-TR-I062 (V2.4)		
连云港神舟新能源有限公司	文件版本号	V2.4	页码	1 / 46


单玻光伏组件安装说明书

PV Module Installation Instructions




连云港神舟新能源有限公司

Lianyungang Shenzhou New Energy Co.,Ltd

	文件名称	单玻光伏组件安装说明书		
	文件编号	HTL-TR-I062 (V2.4)		
连云港神舟新能源有限公司	文件版本号	V2.4	页码	2 / 46


目录

1 基本信息.....	4
1.1 前言.....	4
1.2 警告.....	4
1.3 产品标识.....	6
2 系统设计.....	9
2.1 气候条件.....	10
2.2 安装地点选择.....	10
2.3 倾斜角选择.....	12
2.4 支架选择.....	13
2.5 逆变器选择.....	14
2.6 双面组件排布与布局优化.....	16
3 安装.....	17
3.1 安装安全.....	17
3.2 组件拆箱.....	19
3.3 安装方法介绍.....	22
3.4 夹具安装.....	23
3.5 螺栓安装.....	33
3.6 单轴跟踪系统安装.....	36
4 电气连接.....	38
4.1 电气连接注意事项.....	38
4.2 组件接线.....	41
5 保养维护.....	42
6 免责声明.....	45

	文件名称	单玻光伏组件安装说明书		
	文件编号	HTL-TR-I062 (V2.4)		
连云港神舟新能源有限公司	文件版本号	V2.4	页码	3 / 46

Contents

1. Basic Information	4
1.1 Preface Introduction	4
1.2 Warnings.....	6
1.3 Product Identification	9
2 System Design.....	10
2.1 Climatic Conditions.....	10
2.2 Location Selection.....	11
2.3 Installation Inclination Angle Selection	12
2.4 Choose the Photovoltaic Support	13
2.5 Choosing the Photovoltaic Inverter	15
2.6 Bifacial Module Arrangement and Layout Optimization	16
3 Installation.....	18
3.1 Installation Safety.....	18
3.2 Modules Unpacking	20
3.3 Introduction of Installation Method	22
3.4 Installation of Clamps	28
3.5 Installation of Bolts	34
3.6 Installation of Single-axis Tracking System.....	37
4 Electrical Connection	39
4.1 Precautions for Electrical Connection.....	39
4.2 Wiring and Connections	42
5 Maintenance	44
6 Disclaimer	45

	文件名称	单玻光伏组件安装说明书		
	文件编号	HTL-TR-I062 (V2.4)		
连云港神舟新能源有限公司	文件版本号	V2.4	页码	4 / 46

1 基本信息

1.1 前言

感谢您选择 连云港神舟新能源有限公司 光伏组件。本手册所指的光伏组件是指由本单位所生产和销售的光伏组件。

本说明书提供了神舟单玻光伏组件（以下简称组件）的安装和安全使用信息。

安装前，请仔细阅读和理解本说明书。如有任何问题，请联系我们的销售部门。

安装人员应熟悉太阳能光伏发电系统的机械和电气要求。安装组件时，安装者应遵守本手册和当地相关法律法规规定的安全注意事项。

根据 IEC61730 标准：太阳能组件安全等级为 Class II；太阳能组件防火等级为 C 级（参考 UL790）。

1. Basic Information

1.1 Preface Introduction

Thanks for choosing PV modules of Lianyungang Shenzhou New energy Co., Ltd.. The PV modules in this manual were manufactured or sold by our company.

This manual contains the information of installation and safe operation of Shenzhou's PV modules (hereafter referred to as "module").

All instructions should be read carefully before installation. Please contact our sales department for more information if you have any question.


The installer should be familiar with the mechanical and electrical requirement of PV system. The installer should comply with safety precautions listed in this manual and local law regulations when installing the modules.

According to IEC61730 standard, the safety class of solar module is class II; the fire protection grade of solar module is class C (refer to UL790).

1.2 警告

1.2.1 安装太阳能光伏发电系统要求专业的知识和技能，必须由具备专业资格的工程师操作。

1.2.2 当组件暴露在太阳光或者其他光源下，组件内有直流电流产生，此时与组件的电气部分接触可能会发生触电危险。

	文件名称	单玻光伏组件安装说明书		
	文件编号	HTL-TR-I062 (V2.4)		
连云港神舟新能源有限公司	文件版本号	V2.4	页码	5 / 46

1.2.3 将组件应用于地面、屋顶等室外环境。如果组件安装在屋顶的话，必须安装在具有一定防火能力的屋顶上，可以咨询当地的建筑部门来决定使用何种屋顶材料。组件不能替代屋顶及墙体材料，部分替代也不允许。合理的支撑结构是系统设计人员或安装人员的责任。

1.2.4 当负载工作时，不要擅自断开组件的连接。

1.2.5 不要拆解组件、移动任何铭牌或黏附的部件。

1.2.6 不要将组件放置在容易产生或储存可燃气体的地方。

1.2.7 不得用人工聚集的阳光照射在组件上，不能将组件背面直接长时间暴露在阳光下。

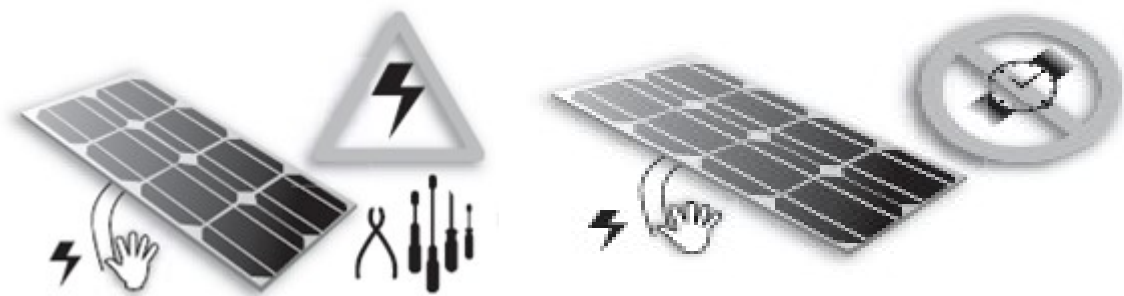
1.2.8 不能让任何物件掉落或覆盖在组件上，严禁在组件上踩踏、站立或行走，因为这样会损坏组件，并有可能对人造成伤害。



1.2.9 禁止通过拉拽组件接线盒电缆的方式移动组件。


1.2.10 在运输和安装过程中严禁孩子接触组件。

1.2.11 在运输和安装过程中，操作员请勿佩戴金属环、手镯、耳环、鼻环、唇环或其他金属饰件。禁止用手直接接触组件的电气部分，使用符合电力安装工作绝缘要求的工具进行电气连接。



1.2.12 在运输过程中，确保组件不会受到撞击、剧烈震动。因为撞击、剧烈震动有可能造成组件内的电池片隐裂。组件运到安装地以后，如果不能及时安装，需放置在平整的地面，并且增加防潮、防风、防雨雪的防护措施。所有的包材都应该小心拆包。

1.2.13 不能损坏组件的玻璃，玻璃具有保护组件的作用。不要损坏组件边缘的密封，否则将导致组件失效。破损的太阳电池组件具有危险性（电击和着火），这样的组件不能修复或维修，应该立

	文件名称	单玻光伏组件安装说明书		
	文件编号	HTL-TR-I062 (V2.4)		
连云港神舟新能源有限公司	文件版本号	V2.4	页码	6 / 46

即换掉。

1.2.14 为降低发生电击或燃烧的风险，可以在安装太阳能电池组件时用不透光材料覆盖在组件表面。

1.2.15 安装人员需确保支架与光伏组件之间的连接牢固、无松动。

1.2.16 所有组件边框和安装架必须按照相应的《国家电气规程》正确接地。

1.2.17 不要用具有腐蚀性的化学药剂来擦拭组件。

1.2.18 屋顶安装会影响房屋的防火性能；根据 IEC61730 的规定，组件的耐火等级为 C 级（参考 UL790）。光伏系统的消防等级应与屋顶一起评估，只有按照安装说明书中规定的方式安装时，组件的防火等级才有效。

1.2.19 组件在储存、运输、安装、维护过程中，严禁与任何形式的油污、具有腐蚀性的化学试剂接触。

1.2 Warnings

1.2.1 It requires specialized skills and knowledge for installation of solar photovoltaic systems. It should be operated by professional installation personnel who have qualified licensed.

1.2.2 When the modules are exposed to sunlight or other light sources, DC current is generated in the modules. At this time, if touching the electrical part of the modules, it may happen electric shock hazard.

1.2.3 The modules could be installed in outside environment, such as ground, roofs etc. If the modules are installed on the roof, the roof should have a certain fire protection capability. It can consult the local construction department to decide the roof material. Do not use this module to replace the whole or partial roofs/walls of living buildings. The system designer or installer have responsible for reasonable support structure.


1.2.4 Do not disconnect any of the modules connector during work.

1.2.5 Do not disassemble modules or move nameplate or any adhesion parts of modules.

1.2.6 Do not place the modules where it is easy to full of combustible gases.

1.2.7 Do not use Artificially concentrated sunlight on the module. Do not expose the back of the module to sunlight for a long time.

1.2.8 Avoid dropping or covering on the modules. Do not tread, stand or walk on modules, because there is a risk of damage to the module and harm to person.

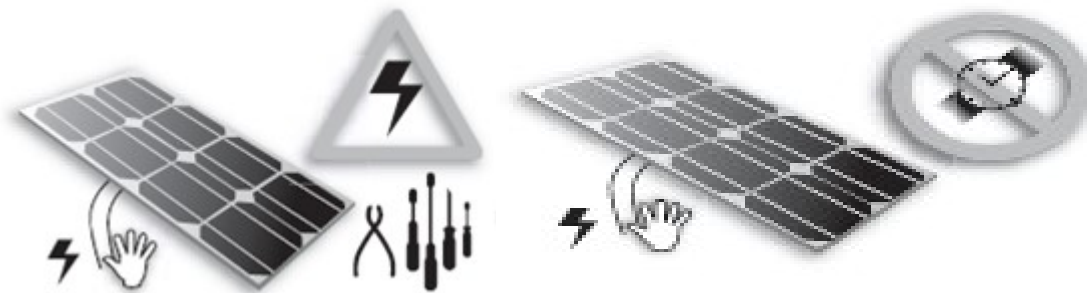
	文件名称	单玻光伏组件安装说明书		
	文件编号	HTL-TR-I062 (V2.4)		
连云港神舟新能源有限公司	文件版本号	V2.4	页码	7 / 46



1.2.9 Avoid moving the modules by pulling cables or the junction box.

1.2.10 Keep children away from modules during transportation and installation.

1.2.11 Avoid wearing metal rings, bracelet, earrings, nose rings, lip rings or any metal accessories during transportation and installation of the modules. Do not touch electrical part of the modules by hand without any insulated protection. Use insulated tools which satisfy electrical requirement to connect electrical parts of the modules.




1.2.12 During transportation of the modules, please make sure that any impact and strenuous vibration should be avoid. The impact and strenuous vibration have possible to lead cracks of solar cell in the modules. When the modules arrive the destination, before installation, the module should be placed on the flat ground with protection which has ability to avoid moisture, wind, rain and snow. Please unpack carefully.

1.2.13 Avoid any damage of the glass of the module, which can protect the modules. Avoid any damage of the seal on the edge of the modules. Without seal protection, the modules have risk of destroy. The damage modules have risk of electric shock or fire. The damage module can't be repaired. If there is any damage on the modules, please replace the modules immediately.

1.2.14 In order to reduce the risk of electric shock or combustion, opaque material can be used to cover the front surface of the modules during installation.

1.2.15 Installers should make sure firm connections between the rack and PV module without loose

	文件名称	单玻光伏组件安装说明书		
	文件编号	HTL-TR-I062 (V2.4)		
连云港神舟新能源有限公司	文件版本号	V2.4	页码	8 / 46

connections.

1.2.16 The frame and support of all modules should be grounded correctly, according to “National Electrical Code”.

1.2.17 Do not clean the modules with corrosive chemicals.

1.2.18 It is possible to affect fire resistance of the house if roof-mounted. According to IEC61730, the level of fire resistance of modules, which is installed on roof, is Class C (refer to UL790). For roof application, the estimate of fire control level of module system should combine module and roof condition. Only correct installation, which accords to installation instruction, the fire resistance of module system is effective.

1.2.19 During the storage, transportation, installation and maintenance of components, it is strictly prohibited to contact with any form of oil stain or corrosive chemical reagent.

1.3 产品标识

1.3.1 每个组件的背面都有标签，一般提供以下信息：


产品类型、重量、尺寸、熔丝电流、系统最高电压、标准测试条件下测得的额定功率、额定电流、额定电压、开路电压、短路电流。

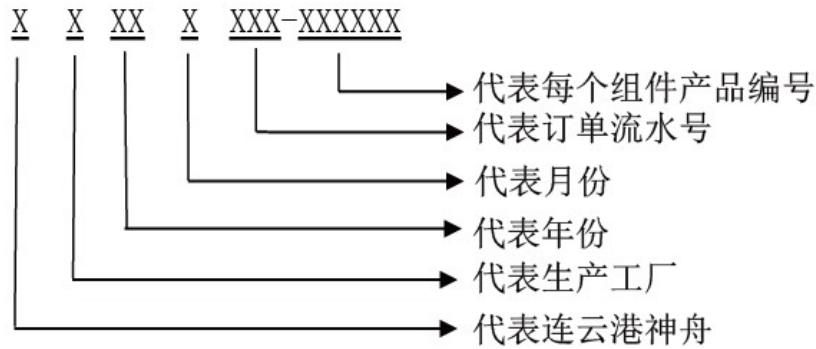
1.3.2 条形码（序列号）：每个组件都有一个唯一的序列号。它被永久地固定在组件内部，从组件正面可以看到。



图 1 条形码

1.3.2.1 组件条码由 14 位数码及划线组成。组件的序列号具有唯一性，其含义为：前八位为两位生产工厂码、三位日期码和三位订单流水号组成，八位后为一划线，划线后六位即为组件生产流水号，一个工单的组件数量不得超过 999999 块。

	文件名称	单玻光伏组件安装说明书		
	文件编号	HTL-TR-I062 (V2.4)		
连云港神舟新能源有限公司	文件版本号	V2.4	页码	9 / 46



1.3 Product Identification

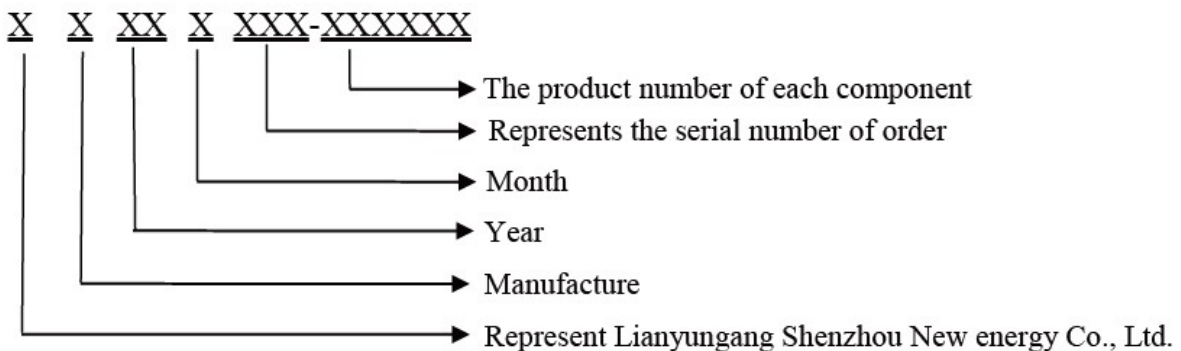
1.3.1 Each module has a label on the back, generally containing following information: product type, weight, size, fuse current, the system max voltage, rated power measured under standard test conditions, rated current, rated voltage, open circuit voltage, short circuit current.


1.3.2 Bar code (serial number): each module is registered with a unique serial number. It is fixed in the module permanently. It can see the bar code in front of the module.



Figure1 Bar Code

1.3.2.1 The unique bar code (serial number) of the module consists of 14 bits and a line. The first eight digits of serial number are composed of two manufacture codes, three date codes and three order serial Numbers. The line is followed by six digit numbers of module production code. The number of module in each order will not exceed 999999.



	文件名称	单玻光伏组件安装说明书		
	文件编号	HTL-TR-I062 (V2.4)		
连云港神舟新能源有限公司	文件版本号	V2.4	页码	10 / 46

2 系统设计

2.1 气候条件

2.1.1 相对湿度：<85%。

2.1.2 组件运行的温度在-40℃-85℃。

注意：计算组件机械载荷（包括风和雪的压力）时给考虑安装方法和安装地点，计算机机械载荷时必须由专业的人员根据系统的设计要求进行计算。

2 System Design

2.1 Climatic Conditions

2.1.1 Relative humidity: < 85%.

2.1.2 The operating temperature of the module is - 40 °C - 85 °C.

Note: When calculating the mechanical load of components (including the pressure of wind and snow), the installation method and installation site should be considered. The calculation of mechanical load must be carried out by professional personnel according to the design requirements of the system.


2.2 安装地点选择

2.2.1 HT 组件允许的最大安装高度是海拔 2000 米。

2.2.2 在标准测试条件下(1000 W / m²的辐照度,AM 1.5, 25℃(77°F)环境温度), 组件的电气性能参数如 P_{max} 的标称值与标准测试条件下存在±3%的误差, I_{sc}、V_{oc} 的误差为±5%。

2.2.3 在北半球组件建议朝南, 在南半球建议朝北。

2.2.4 太阳能组件的倾斜角指的是组件表面与地平面之间的夹角, 如下图 2 所示, 组件表面与太阳光垂直的时候功率输出最大。建议组件安装角度不小于 10 度。要了解最佳的安装倾斜角的详细信息, 请参考咨询当地可靠的太阳能系统安装公司。

	文件名称	单玻光伏组件安装说明书		
	文件编号	HTL-TR-I062 (V2.4)		
连云港神舟新能源有限公司	文件版本号	V2.4	页码	11 / 46

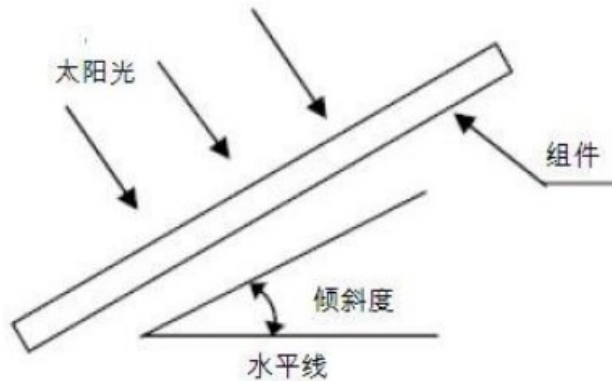


图 2 太阳能组件安装倾斜角

2.2.5 组件应安装在阳光充分照射的地方，不能在任何时间被遮挡。

2.2.6 一般来说，不建议安装在距海边 500 米以内的地方。组件安装在距海边 3 千米以外的地方，可以保证 25 年的使用寿命。如果组件安装在距海边 500 米至 3000 米的地方，组件需要增加额外的保护（如增加铝合金边框的氧化膜厚度，并且对安装部位做好防锈蚀的处理）。

2.2.7 当组件发电系统用到蓄电池时，蓄电池必须正确安装，这样可以保护组件发电系统的安全运行。蓄电池的安装使用维护需按照蓄电池生产商说明书进行。

2.2.8 建议组件离地高度根据实际环境可选择在 0.3-1m 之间。


2.2 Location Selection

2.2.1 The maximum altitude for HT PV module is 2000m.

2.2.2 At standard test conditions (1000W / m² irradiance, AM 1.5 spectrum, 25 ° C (77 ° F) ambient temperature), the test error of module electrical performance parameters of modules, such as I_{sc}, V_{oc}, and P_{max}, is ±3% for P_{max} and ±5% for V_{oc} and I_{sc}.

2.2.3 In the northern hemisphere, it advises that the modules face to south direction. In the southern hemisphere, it advises that modules face to north direction.

2.2.4 The tilt angle of the PV module is the angle between the surface of the PV module and a horizontal ground surface (as shows in Figure 2). The PV module generates maximum output power when it faces the sun vertically. It is recommended that the installation angle of the module is bigger than 10 degrees. If you want the specific information of the best install tilt angle, please consult reliable local photovoltaic system installation companies.

	文件名称	单玻光伏组件安装说明书		
	文件编号	HTL-TR-I062 (V2.4)		
连云港神舟新能源有限公司	文件版本号	V2.4	页码	12 / 46

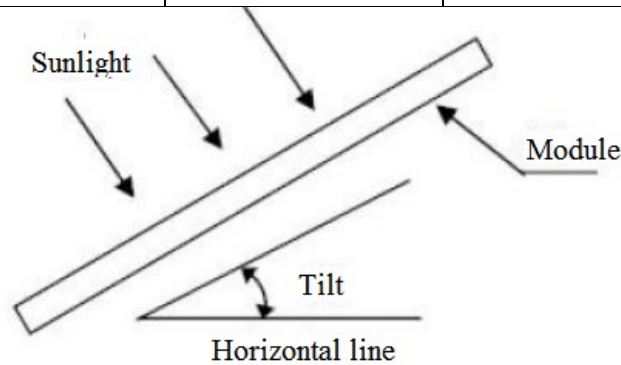


Figure 2 PV module tilt angle

2.2.5 The modules should be installed in the position where is full of sun exposure without shadow at any time.

2.2.6 Generally, it is not recommended to be installed in the place where is less than 500 meters from the sea. The modules, as a general rule, can guarantee 25 years of useful life if the module is installed in the place where is more than 3 km from the sea. If the module is installed in the place where is 500-3000m to the sea, the modules need extra protection. (For example, increasing the thickness of the oxide film of Aluminum metal alloy frame, and increasing the anti-corrosion treatment of frame connection.)

2.2.7 When a storage battery is used in the photovoltaic system, the battery must be installed correctly. Therefore, it can protect the safety of photovoltaic system. The installation of the storage battery should follow the instructions of storage battery manufacturer.

2.2.8 It is recommended that the height of the module is 0.3-1m higher than actual environment.

2.3 倾斜角选择


2.3.1 串联连接的光伏组件应按照相同的朝向和角度进行安装。

2.3.2 如果连接到独立光伏系统，组件的安装角度应该根据季节和光照的情况来获得最大化的功率输出，一般来讲，如果组件的输出在一年内光照强度最低的情况下也可以满足的话，那所选择这个角度的组件输出就能满足全年的需求；对于并网连接的系统，组件的安装角度应该基于全年的输出最大化这个基础原则来选择。

2.3 Installation Inclination Angle Selection

2.3.1 PV modules connected in series should be installed in the same orientation and angle.

2.3.2 If connected to an independent photovoltaic system, the installation angle of the module should be based on the season and light conditions to achieve the maximum power output. At the lowest

	文件名称	单玻光伏组件安装说明书		
	文件编号	HTL-TR-I062 (V2.4)		
连云港神舟新能源有限公司	文件版本号	V2.4	页码	13 / 46

illumination intensity, if the power generated by module with certain angle can satisfy the lowest power generation, it is think that the modules with the certain angle can satisfy the power generation all year around. For grid-connected system, the installation angle of modules depends on the max power generation all year around.

2.4 支架选择

系统设计者或安装者负责载荷计算，使组件能够承受所有预定的载荷条件；这是支架安装商所必须要提供的保证。所选用的支架必须经过具有静态力学分析能力的第三方测试机构检验和测试。

2.4.1 双面组件支架不遮挡背面电池片

在支架结构设计时，支架构件不能横穿组件电池片区域，只能在组件边沿设置斜梁及连接辅件，同时逆变器安装位置也不能在组件背后，而应该安装在组件侧面，避免影响到组件背面的反射光。

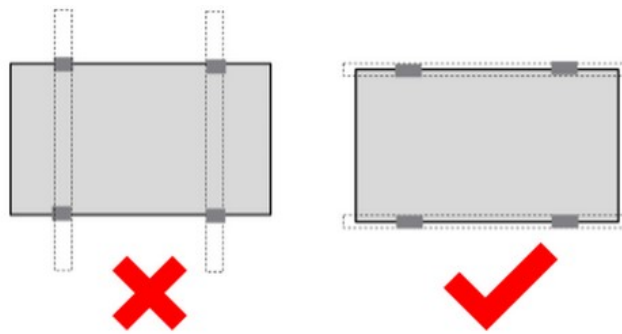



图 3 双面组件支架不遮挡背面电池片

2.4 Choose the Photovoltaic Support

The system designer or installer have responsible for calculation the system load to make sure all module can support the estimated load. The module support manufactures should supply qualified module supports. The support, which is used for photovoltaic system, should has the third test institution certification about static mechanical analysis ability.

2.4.1 Installation of bifacial module without shading the back of module

When designing the modules' support structure, the support components cannot cross the module cell area. The support components can be set up at the edge of the module. At the same time, the inverter should be installed at the side of the module instead of back. If the inverter is installed at the back of the module, it may reduce the reflected light and reduce power generation of the back of the module.

	文件名称	单玻光伏组件安装说明书		
	文件编号	HTL-TR-I062 (V2.4)		
连云港神舟新能源有限公司	文件版本号	V2.4	页码	14 / 46

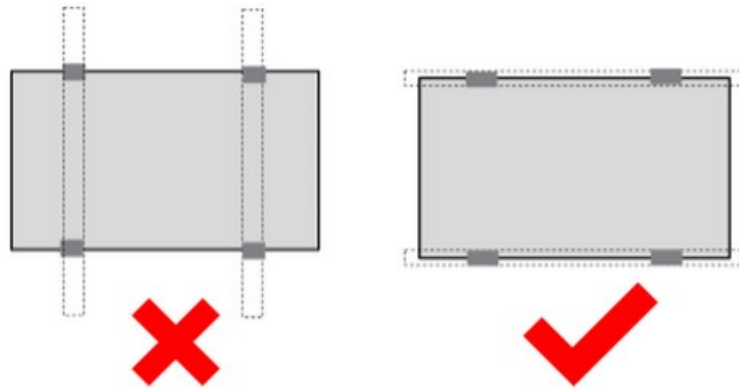


Figure 3 The support components do not cover the back battery

2.5 逆变器选择

在选择逆变器类型时，需要考虑光伏组件阵列的输出功率、开路电压、短路电流。组件阵列的最小电压应大于逆变器的开启电压，以保证逆变器的正常工作。

2.5.1 阵列串联组件数量计算


请使用与太阳能系统配套的设备、连接器、电线、支架。在特定的系统中，一定要使用相同类型的组件。在确定光伏系统相关部件的额定电压、导线容量、保险丝容量、控制器容量等和组件输出功率有关联的参数时，请参照组件标签上显示的短路电流(Isc)和开路电压(Voc)的值进行合理的设计。

在正常的室外环境下，光伏组件产生的电流和电压可能与参数表中的参数不同。参数表中的参数是在标准测试条件下(STC)测得，所以关于解决不同地区的光伏发电系统的参数，如额定电压、导线容量，保险丝容量，控制器容量和组件输出功率时，应使用组件标签上的 Isc 和 Voc 的值应乘以 1.25 倍的冗余值设计和安装。若双面发电的组件安装在背面环境反射条件好的地方，需适当增加冗余值。

确保每个阵列的系统电压不超过组件最大系统电压，以及控制器、逆变器等子设备的额定电流和电压。

组件之间的连接：根据系统设计要求输出电压和电流，组件通过自身导线串联或并联起来；串联组件的最大数量（N）建议使用下列公式计算；并联组件的数量与标准测试条件下选择的电气设备（逆变器、控制器）有关。

$$N \leq \frac{V_{max}}{V_{oc} * [1 + T_c(voc) * (T_{min} - 25)]}$$

	文件名称	单玻光伏组件安装说明书		
	文件编号	HTL-TR-I062 (V2.4)		
连云港神舟新能源有限公司	文件版本号	V2.4	页码	15 / 46

N 串联组件数量。

V_{max} 最大系统电压（见产品标签或数据表）。

V_{oc} 组件开路电压（见产品标签或数据表）。

T_{c(voc)} 组件开路电压温度系数(参见数据表)。

T_{min} 最低环境温度。

2.5 Choosing the Photovoltaic Inverter

When choosing photovoltaic inverter, it needs consider the power, open-circuit voltage, short-circuit current of PV modules array. The minimum voltage of the module array should be higher than the threshold voltage of inverters to guarantee the inverters regular work.


2.5.1 Calculation of modules' number in series array

Please use the suitable equipment, connectors, wires and rack which match with solar power system. Please make sure the type of the modules is same in a single PV system. When determining rated voltage, wire capacity, fuse, the controller capacity and module output power of relevant parts of PV system, please accord to the short-circuit current (I_{sc}) and open circuit voltage (V_{oc}) showing on modules' label to determine suitable parameters.

In normal outdoor conditions, the current and voltage generated by module may be different from the parameters listed in Table. The parameter list in table is measured under standard test conditions (STC). In different outside climate surrounding, because of different power generation coefficient, the actual parameters, including rated voltage, wire capacity, fuse, the controller capacity and module power output, is different if modules working in different area. In order to get the actual module's electrical parameters, usually, the photovoltaic system designers or installers can use short-circuit current (I_{sc}) and open circuit voltage (V_{oc}) noted on modules' label multiply by 1.25 (redundant value). If the bifacial modules are installed at high reflective surrounding, the redundant value can increase suitably.

Please make sure the system voltage of each modules' array is lower than the maximum voltage of photovoltaic system, rated voltaic of inverter and controller. The system current of each modules' array is less than maximum current of photovoltaic system, rated current of inverter and controller.

The connection of modules: According to the system requirement of output voltage and current, modules are connected in series or parallel. The maximum number of series components (N) is

	文件名称	单玻光伏组件安装说明书		
	文件编号	HTL-TR-I062 (V2.4)		
连云港神舟新能源有限公司	文件版本号	V2.4	页码	16 / 46

recommended to be calculated using the following formula. The number of modules in parallel has relate to the parameters of electrical equipment (such as inverter and controller) in STC.

$$N \leq \frac{V_{max}}{V_{oc} * [1 + T_c(voc) * (T_{min} - 25)]}$$

N Number of modules in series.

V_{max} Maximum system voltage

V_{oc} Open circuit voltage of each module(refer to product label or data sheet).

T_c(voc) Thermal coefficient of open circuit voltage for the module(refer to data sheet).

T_{min} The lowest ambient temperature.

2.6 双面组件排布与布局优化

对于标准方阵而言，一般的接线方式是两种，第一种上下串联，第二种上下分开串联。下面一行的距地高度和上面一行的距地高度是远远不同的（尤其是在组件竖向布置时）。而此时，在进行组串接线时，如果选择方式1，受下面一行组件低电流的影响，上面一行组件的电流也会降低，从而使得整体的输出功率有所降低。而如果采用方式2，此时上下两行单独成串，互不影响，充分的利用的双面组件的性能，提高了发电量。上下排组件的增益效果是不同的，上排的组件增益相对较高，下排的组件增益相对较低，为了降低组串的失配，我们还是建议有条件的选择方式2的组串形式，同时将上下两串接入逆变器的不同 MPPT 下，这就是目前最优的接线方式。

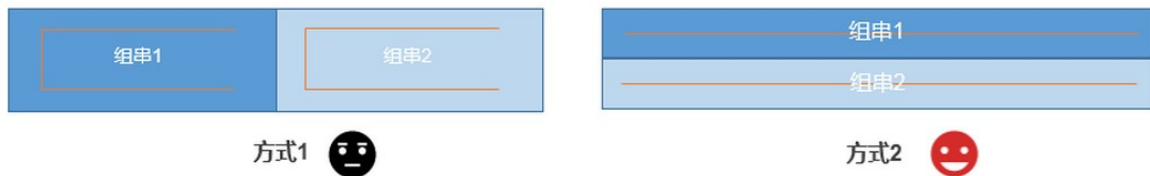



图4 组串接线优化

2.6 Bifacial Module Arrangement and Layout Optimization

Generally, for normal modules' array, there are 2 methods of module connection. The first method connects the upper module and the under module in series. The second method separates the upper and the under modules. All upper modules connect in series, and all under modules connect in series separately. There is significant height difference between upper and under modules. The significant height difference lead to light illumination difference between upper and under modules. The light illumination difference lead different working current of the module. If choosing the first method, the under module, which has

	文件名称	单玻光伏组件安装说明书		
	文件编号	HTL-TR-I062 (V2.4)		
连云港神舟新能源有限公司	文件版本号	V2.4	页码	17 / 46

lower working current, will decrease the working current of the upper module. The decreasing of upper modules' working current will reduce the whole power generation of photovoltaic system. When choosing the second method, the upper modules and the under modules have different working current. It can decrease power loss due to working current mismatch, which improves the advantage of bifacial modules and increases whole power generation of photovoltaic system. The light illumination rises with height increasing at the same outside surrounding. Therefore, the upper modules have higher light illumination than the under modules. In order to declining the current mismatch, we advise the second modules connection method. At the same time, please connect the upper/under modules' array to the different MPPTs of the inverter individually. This is the best method of modules' array connection for photovoltaic system.

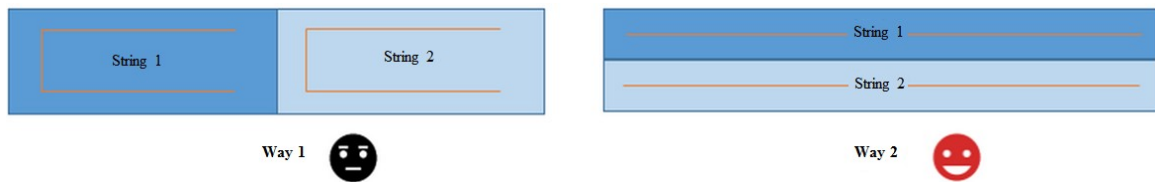



Figure 4 Optimization of modules' array connection

3 安装

3.1 安装安全

- 3.1.1 组件安装的时候要戴上防护头盔、绝缘手套，穿上橡胶鞋。
- 3.1.2 在安装的过程中，不能站到组件上，那样行为会损坏组件，也会危及人身安全。避免不必要地去触摸组件，组件表面和边框可能很热，会有烧伤或者电击的危险。
- 3.1.3 安装的时候再拆开组件包装。不要在下雨，下雪或者大风的天气条件下安装。
- 3.1.4 由于有电击的危险，如果组件的接线盒端子是湿的，请不要进行安装作业。
- 3.1.5 安装时，禁止乱摔任何东西，包含组件和安装工具。
- 3.1.6 正确无误的连接接线盒连接器，检查接线状况，所有的连接线不得脱离组件，并采取一定的方式使连接线不会擦伤或者挤压组件。
- 3.1.7 不管组件有没有连接到光伏系统，在安装过程或者是有光照照在组件上的时候，请不要裸手接触接线盒或者连接器。
- 3.1.8 不要在组件表面加过重力或者物体，或扭曲组件的边框。

	文件名称	单玻光伏组件安装说明书		
	文件编号	HTL-TR-I062 (V2.4)		
连云港神舟新能源有限公司	文件版本号	V2.4	页码	18 / 46

3.1.9 禁止在组件的玻璃上放过重的物体或者进行撞击，这可能会损坏电池片或者造成电池片隐裂。

3.1.10 禁止使用尖锐的工具去擦洗组件的玻璃，这会在组件上留下划痕。

3.1.11 不要擅自在组件边框上钻孔。

3.1.12 对于 BIPV 或安装在屋顶的结构，需要有计划的施工，请尽量遵循“从上到下”或/和“从左到右”的安装规则。

3 Installation

3.1 Installation Safety

3.1.1 Wear protective headgear, insulating gloves and rubber shoes when modules are installed.

3.1.2 During installation, avoid standing on the modules, which will lead to damage of modules, or hazard human safety. Avoid unnecessary touching of modules. The surface and frame of modules may be very hot, which may lead to burn or electric shock.

3.1.3 Don't unpack the outside packing of modules except to install immediately. Avoid installing in rainy, snowy or windy weather.

3.1.4 In order to reduce hazard of electric shock, if the junction box connectors are wet, stop installing.

3.1.5 During installing, do not throw anything, including modules and installation tools.


3.1.6 Please make sure connecting junction box correctly. Checking wiring status to ensure that all strong connection without broken. Take adequate measure to avoid any scratch which may damage the cables or pressure which may damage the module.

3.1.7 During installation or sunshine, avoid touching the junction boxes or connectors no matter what the modules are connecting with photovoltaic system or not.

3.1.8 Avoid pressing or putting something heavy on the module's surface or distorting the module's frame.

3.1.9 Avoid setting overweight things or hitting on the module's surface glass, which may lead damage or microcrack of the solar cell.

3.1.10 Avoid cleaning the modules with sharp tools, which may lead to scratch on the surface of modules.

	文件名称	单玻光伏组件安装说明书		
	文件编号	HTL-TR-I062 (V2.4)		
连云港神舟新能源有限公司	文件版本号	V2.4	页码	19 / 46

3.1.11 Avoid digging holes on the module's frame without permission.

3.1.12 For BIPV or roof application, please installing in plan. Please follow the installation rules of "from top to bottom" or / and "from left to right" as much as possible.

3.2 组件拆箱

3.2.1 当组件被运到安装地，应避免在雨天对组件进行拆箱。

3.2.2 拆箱后的组件应水平放置，禁止倾斜、堆压重物、斜靠等堆栈方式。

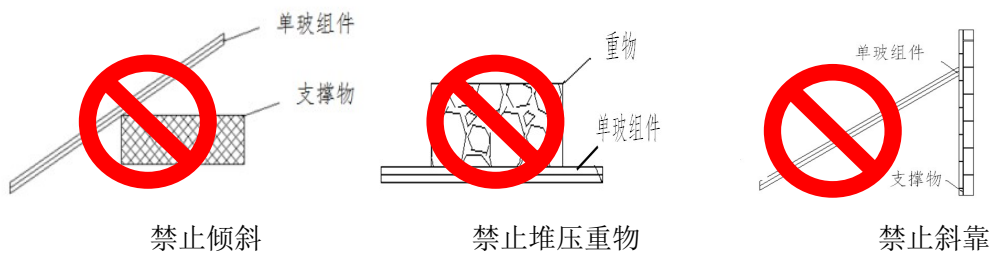



图 5 组件堆放说明

3.2.3 两个批次的组件之间分开，整齐堆放。组件重量不超过 20kg 的组件每托堆放数量不超过 24 块；组件重量超过 20kg 的组件每托堆放数量不超过 20 块。

3.2.4 包装箱拆箱需按下图进行拆箱，禁止野蛮操作或用撬棍插入箱内撬开，使用工具时注意人身安全与组件安全。

3.2.5 包装箱卸车后，需放置在干燥、平整的地面上，不得放置在潮湿、泥泞、凹凸不平的地面上。

3.2.6 组件运抵施工项目地后，需要将上下箱拆开单独放置，不得将两箱组件摞托放置；如组件无法及时安装，需注意组件及包装箱的保护，防止雨水、大雪、冰雹、台风等自然灾害的破坏。

	文件名称	单玻光伏组件安装说明书		
	文件编号	HTL-TR-I062 (V2.4)		
连云港神舟新能源有限公司	文件版本号	V2.4	页码	20 / 46

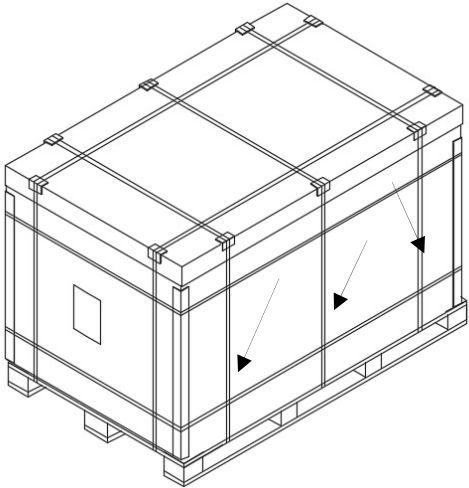
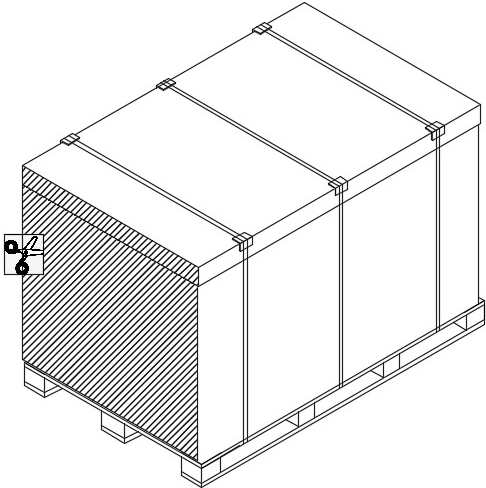
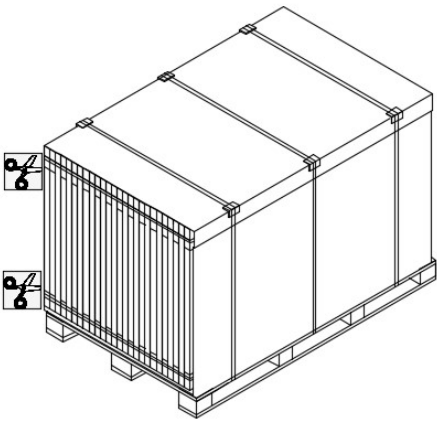
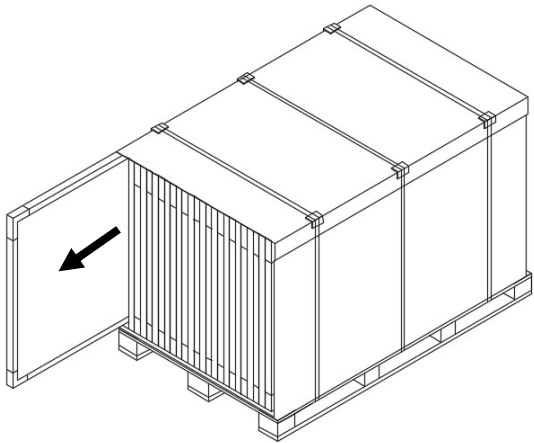

拆箱过程：	
	
1. 箭头所指 3 根打包带不拆，拆除其余外箱打包带	2. 去除包装侧面（阴影部分）
	
3. 剪断纸箱内部的上下两根横向打包带	4. 拆卸组件，根据现场环境做好防倾斜措施

图 6 拆箱过程图

3.2 Modules Unpacking

3.2.1 When the modules arrival to destination, avoid unpacking modules in humid and rainy weather.

3.2.2 After unpacking, the modules should be placed horizontally. Avoid tilt, pressure, leaning on the wall of the modules.

	文件名称	单玻光伏组件安装说明书		
	文件编号	HTL-TR-I062 (V2.4)		
连云港神舟新能源有限公司	文件版本号	V2.4	页码	21 / 46

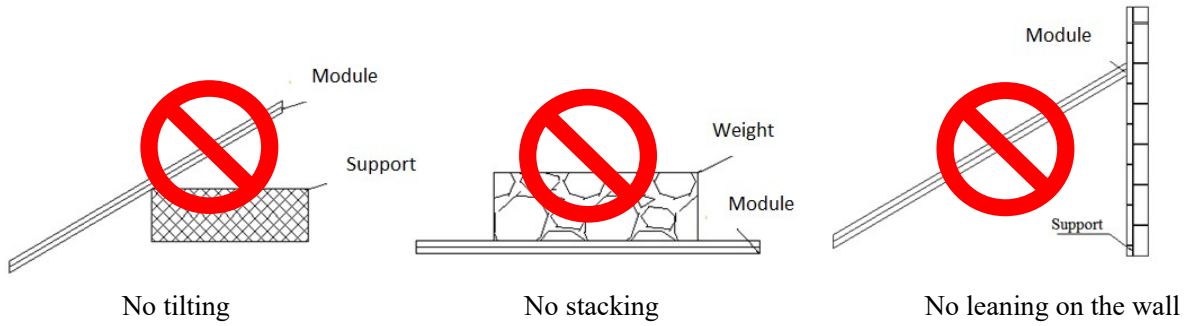


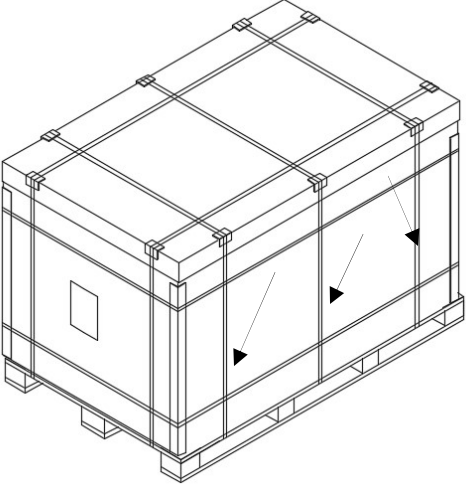
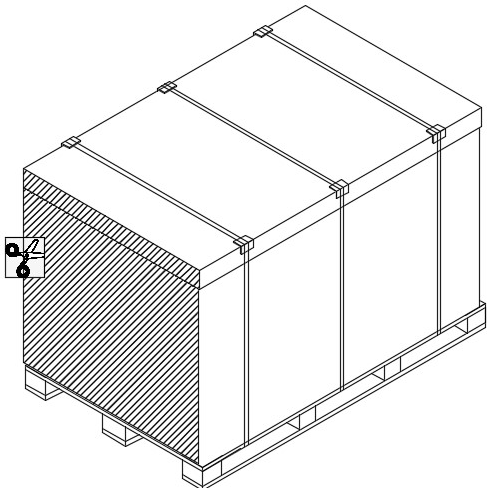
Figure 5 Modules stack illustration


3.2.3 The modules of two batches are separated and stacked neatly. The weight of modules' stack should not exceed 20kg. The number of modules per stack is less than 24pcs. If the weight of module exceeds 20kg, the number of modules per stack is less than 20pcs.

3.2.4 Unpacking process should follow the instructions as the figure below. Avoid rude operation or using crowbar to open the boxes. Pay attention to person and modules safety during unpacking.

3.2.5 After unloading, the modules' box should be placed on dry and flat ground, without wet, muddy and uneven ground condition.

3.2.6 After arriving the destination, the upper and lower modules' boxes should be separated and placed separately without stack. If the modules cannot be installed immediately, it should be care to protect the package of modules' boxes. Avoid any packing damage from natural disasters such as rain, snow, hail, typhoon, etc.

Unpacking process	
	
1. Do not remove the 3 packing belts indicated by the arrow, and remove the other packing	2. Remove one side of the package (shaded part).

	文件名称	单玻光伏组件安装说明书		
	文件编号	HTL-TR-I062 (V2.4)		
连云港神舟新能源有限公司	文件版本号	V2.4	页码	22 / 46

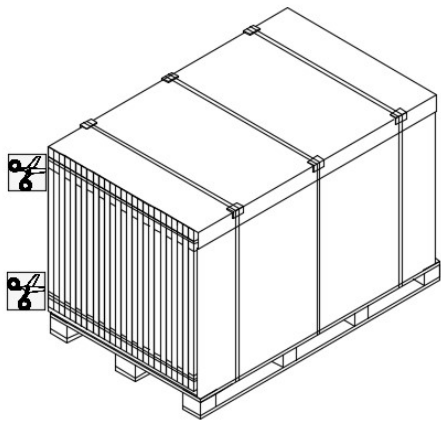
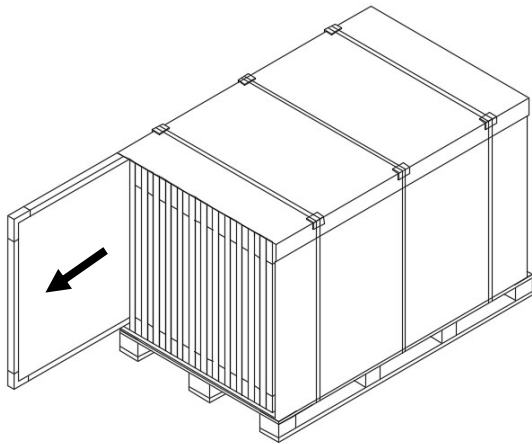
belts of the package.	
	
3. Cut the two horizontal packing belts in the carton.	4. Disassembly modules from side. According actual surrounding, avoid tipping over or sliding of unpacking modules.

Figure 6 Unpacking process

3.3 安装方法介绍

组件的安装可以采取以下的方式：夹具安装和螺栓安装。

3.3.1 本说明书介绍的所有安装方式只供参考，我司不负责提供相关的安装部件，组件系统的设计、安装。机械载荷和安全性必须由专业的系统安装商或者有经验的人来完成。

3.3.2 安装前，还需要确认以下重要的几项：

a) 安装之前需检查一下外观是否有缺陷或其它杂物以及接线盒的安全性能，如果有的话，需清除。

b) 检查组件的序列号是否正确。

3.3.3 如果组件安装地环境为多雪或强风，在组件安装时应采取特殊的防护，来满足实际要求。


3.3 Introduction of Installation Method

The modules can be installed in the following methods: clamp installation and bolt installation.

3.3.1 All installation methods described in this instruction are only for reference. Our company is not responsible for providing relevant installation parts, design and installation of component system.

Mechanical loading and safety should be finished by a professional photovoltaic system installer or PV system technicians.

3.3.2 Before installation, the following important items need to be confirmed:

	文件名称	单玻光伏组件安装说明书		
	文件编号	HTL-TR-I062 (V2.4)		
连云港神舟新能源有限公司	文件版本号	V2.4	页码	23 / 46

a) Before installation, it is necessary to check than if there is any defects or other foreign matter which is related with appearance and the safety performance of the junction box. If there is any problem, please solve the problem.

b) Please make sure that the serial number of the module is correct.

3.3.3 If the modules are installed in harsh environments, such as snowy or windy, extra measures are needed to protect the modules.

3.4 夹具安装

夹具安装建议使用 M8 螺栓进行固定。夹具必须与组件边框重叠至少 7mm(0.28 英寸)但不超过 10mm(0.39 英寸)。这里介绍的所有安装方式只供参考，我们不负责提供相关部件、组件系统的设计、安装。组件的机械载荷和安全性必须由专业的系统安装商或者具备相关资质的人来完成。

- 在安装支架上至少使用 4 个夹具固定组件。
- 夹具不能遮挡组件正面玻璃，也不能使组件边框变形。
- 确保组件不会产生遮挡效应。
- 组件边框在任何条件下都不能被改变。
- 安装支架不得安装在组件接线盒的正下方。


在选择使用夹具安装方式时，每个组件至少要使用 4 个夹具。根据当地的风载和雪载，可能需要额外的夹具来确保组件能够承受负载（如对于风暴、大雪等严苛的环境导致超出下面列出的安装方式，建议使用至少 6 个夹具安装，请咨询我司技术支持）。

应用扭矩应参考机械设计标准，根据客户使用的螺栓而定，例如：

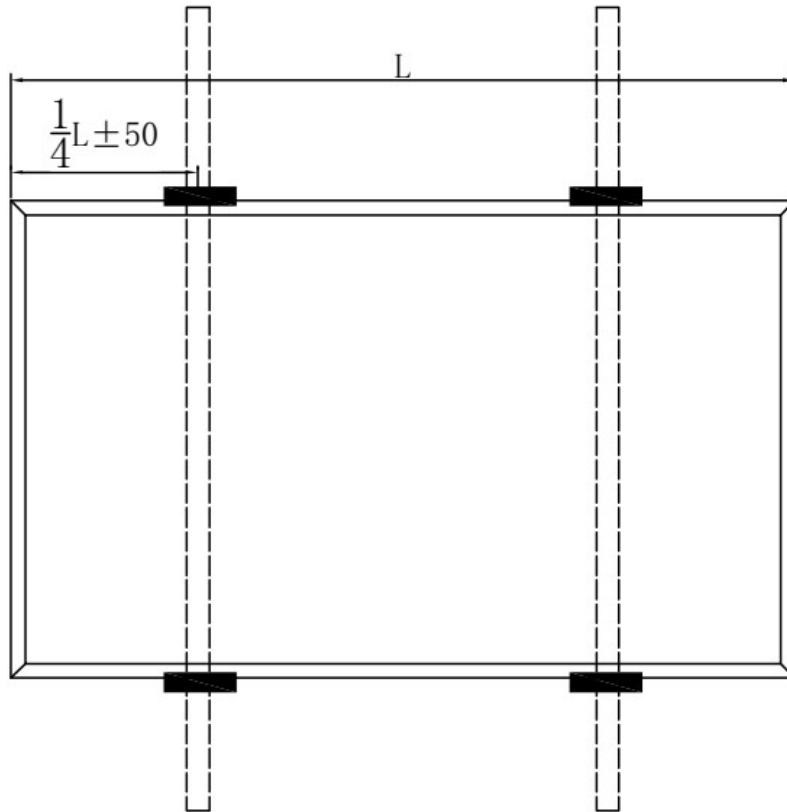
M8 ---- 16-20 N·m。

机械载荷的安全因子为 1.5 倍。

组件有效载荷=设计载荷*机械载荷安全因子倍数（1.5）

	文件名称	单玻光伏组件安装说明书		
	文件编号	HTL-TR-I062 (V2.4)		
连云港神舟新能源有限公司	文件版本号	V2.4	页码	24 / 46


方式一：长边压块安装，设计载荷 $\leq 2400\text{Pa}$ （正面）、 1600Pa （背面）
（使用 4 个压块-压块长度 $\geq 50\text{mm}$ ）



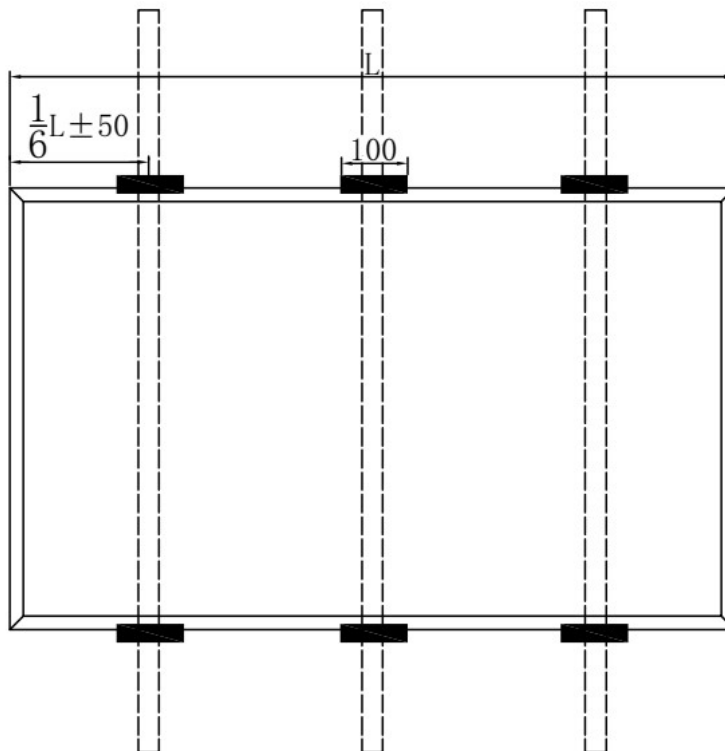
NO.	L*W(mm)
1	1324*992
2	1640*826
3	1640*992
4	1650*992
5	1665*992
6	1665*1002
7	1684*1002
8	1755*1038
9	1775*1052
10	1924*1038
11	1956*992
12	1979*1002
13	1987*992
14	2008*1002
15	2094*1038
16	2115*1052
17	1724*765
18	1722*1134
19	1909*1134
20	2094*1134

注意:

- 1.L 是组件的长边长度，W 是组件短边长度，黑色阴影部分为压块安装范围。
- 2.机械载荷的安全因子为 1.5 倍。

	文件名称	单玻光伏组件安装说明书		
	文件编号	HTL-TR-I062 (V2.4)		
连云港神舟新能源有限公司	文件版本号	V2.4	页码	25 / 46


方式二：长边压块安装，设计载荷≤3600Pa（正面）、1600Pa（背面）
（使用 6 个压块-压块长度≥50mm）



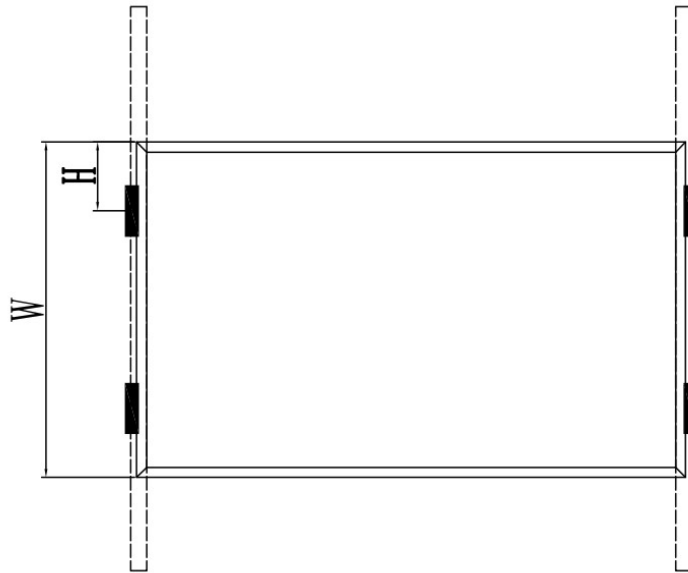
NO.	L*W(mm)
1	1324*992
2	1640*826
3	1640*992
4	1650*992
5	1665*992
6	1665*1002
7	1684*1002
8	1755*1038
9	1775*1052
10	1924*1038
11	1956*992
12	1979*1002
13	1987*992
14	2008*1002
15	2094*1038
16	2115*1052
17	1724*765
18	1722*1134
19	1909*1134
20	2094*1134

注意:

- 1.L 是组件的长边长度，W 是组件短边长度，黑色阴影部分为压块安装范围。
- 2.机械载荷的安全因子为 1.5 倍。

	文件名称	单玻光伏组件安装说明书		
	文件编号	HTL-TR-I062 (V2.4)		
连云港神舟新能源有限公司	文件版本号	V2.4	页码	26 / 46

方式三：短边压块安装，设计载荷 $\leq 1600\text{Pa}$ （正面）、 1600Pa （背面）
（使用 4 个压块-压块长度 $\geq 50\text{mm}$ ）




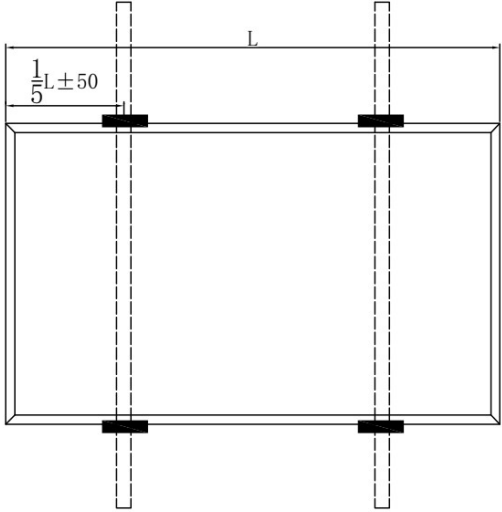
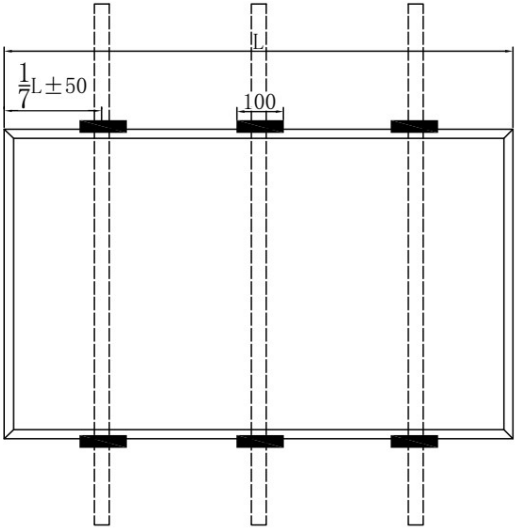
$$0 < H < 1/4 W$$


NO.	L*W(mm)
1	1324*992
2	1640*826
3	1640*992
4	1650*992
5	1665*992
6	1665*1002
7	1684*1002
8	1755*1038
9	1775*1052
10	1924*1038
11	1724*765
12	1722*1134
13	1909*1134

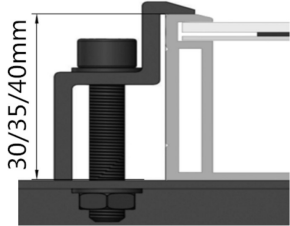
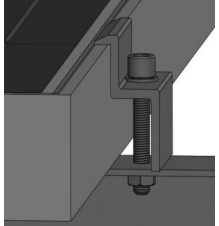
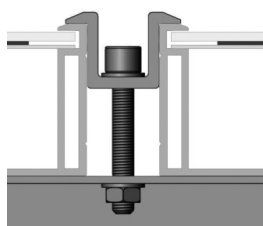
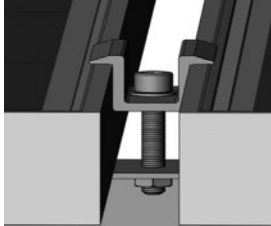
注意:

- 1.L 是组件的长边长度，W 是组件短边长度，黑色阴影部分为压块安装范围。
- 2.机械载荷的安全因子为 1.5 倍。

	文件名称	单玻光伏组件安装说明书		
	文件编号	HTL-TR-I062 (V2.4)		
连云港神舟新能源有限公司	文件版本号	V2.4	页码	27 / 46

<p>方式四（18X 组件 72 和 78 板型）：长边压块安装，设计载荷≤2400Pa（正面）、1600Pa（背面） （使用 4 个压块-压块长度≥50mm）</p>				
	1	2278*1134		
	2	2465*1134		
<p>注意： 1.L 是组件的长边长度，W 是组件短边长度，黑色阴影部分为压块安装范围。 2.机械载荷的安全因子为 1.5 倍。</p>				
<p>方式五（18X 组件 72 和 78 板型）：长边压块安装，设计载荷≤3600Pa（正面）、1600Pa（背面） （使用 6 个压块-压块长度≥50mm）</p>				
	1	2278*1134		
	2	2465*1134		
<p>注意： 1.L 是组件的长边长度，W 是组件短边长度，黑色阴影部分为压块安装范围。 2.机械载荷的安全因子为 1.5 倍。</p>				
单边压块(30/35/40mm 可选)		双边压块		

	文件名称	单玻光伏组件安装说明书		
	文件编号	HTL-TR-I062 (V2.4)		
连云港神舟新能源有限公司	文件版本号	V2.4	页码	28 / 46

			
组件采用夹具安装的安装方式。			

3.4 Installation of Clamps

It suggests to use M8 bolts for module installation. The clamp or belt used for module installation should overlap the aluminium frame. The width of overlap is between 7 mm (0.28 in) to 10 mm (0.39 in). All the installation methods described here are only for reference. We are not responsible for the design of installation part and photovoltaic system installation. Mechanical load and safety of photovoltaic system must be performed by a professional system installer or someone with special certification.

- Use more than 4 clamps to fix modules on the support.
- Modules' clamps, which used for module installation, can't shadow the front surface glass and distort module's frame.
- Avoid shadow on the surface of modules.
- The module frame is not to be modified under any circumstances.
- The mounting bracket shall not be installed directly below the junction box.


When choosing this type of clamp-mounting method, each module needs 4 clamps at least. Depending on local weather, such as wind and snow condition, additional clamps may be required to ensure that modules have enough support. (In case of severe environment such as storm and heavy snow, it is recommended to use at least 6 clamps for installation. Please contact with our technical support for further information.)

- Applied torque should consider mechanical design standard which accords to the bolt used by customer. e.g:

M8 ---- 16-20 N·m.

The safety factor of mechanical load is 1.5 times.

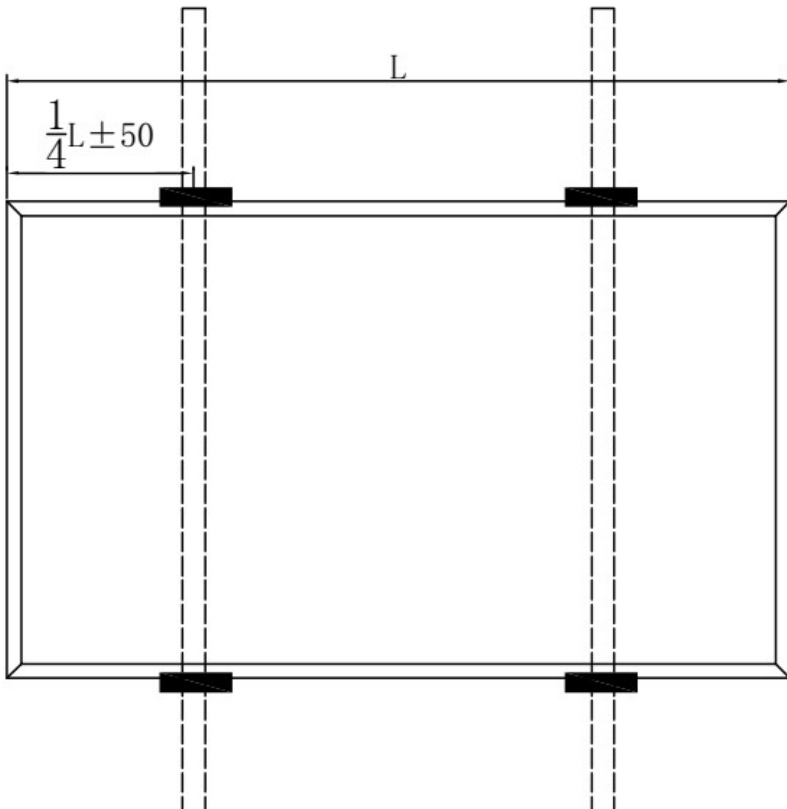
Component payload = design load * mechanical load safety factor multiple (1.5)

	文件名称	单玻光伏组件安装说明书		
	文件编号	HTL-TR-I062 (V2.4)		
连云港神舟新能源有限公司	文件版本号	V2.4	页码	29 / 46

Method 1:

Installation of long side pressing block, design load ≤ 2400 Pa (front), 1600 Pa (back)


(Use 4 clamps- length of blocks ≥ 50 mm)

	NO.	L*W(mm)
		1
	2	1640*826
	3	1640*992
	4	1650*992
	5	1665*992
	6	1665*1002
	7	1684*1002
	8	1755*1038
	9	1775*1052
	10	1924*1038
	11	1956*992
	12	1979*1002
	13	1987*992
	14	2008*1002
	15	2094*1038
	16	2115*1052
	17	1724*765
	18	1722*1134
	19	1909*1134
	20	2094*1134

Notes:

1.L is the length of PV module. W is the wide of module. The black shadow is the area of installation.

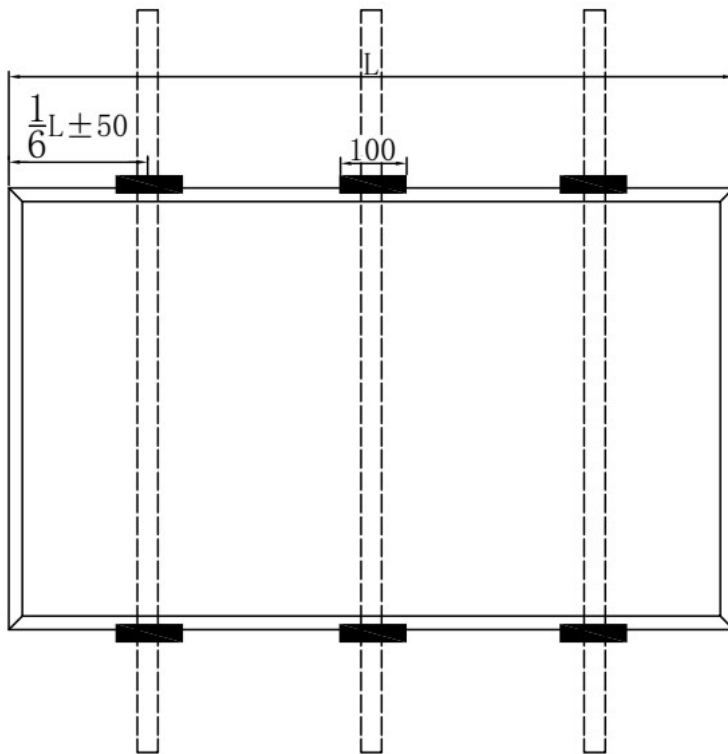
2. The safety factor of mechanical load is 1.5 times.

	文件名称	单玻光伏组件安装说明书		
	文件编号	HTL-TR-I062 (V2.4)		
连云港神舟新能源有限公司	文件版本号	V2.4	页码	30 / 46

Method 2:

Installation of long side pressing block, design load ≤ 3600 Pa (front), 1600 Pa (back)


(Use 6 clamps- length of blocks ≥ 50 mm)



NO.	L*W(mm)
1	1324*992
2	1640*826
3	1640*992
4	1650*992
5	1665*992
6	1665*1002
7	1684*1002
8	1755*1038
9	1775*1052
10	1924*1038
11	1956*992
12	1979*1002
13	1987*992
14	2008*1002
15	2094*1038
16	2115*1052
17	1724*765
18	1722*1134
19	1909*1134
20	2094*1134

Notes:

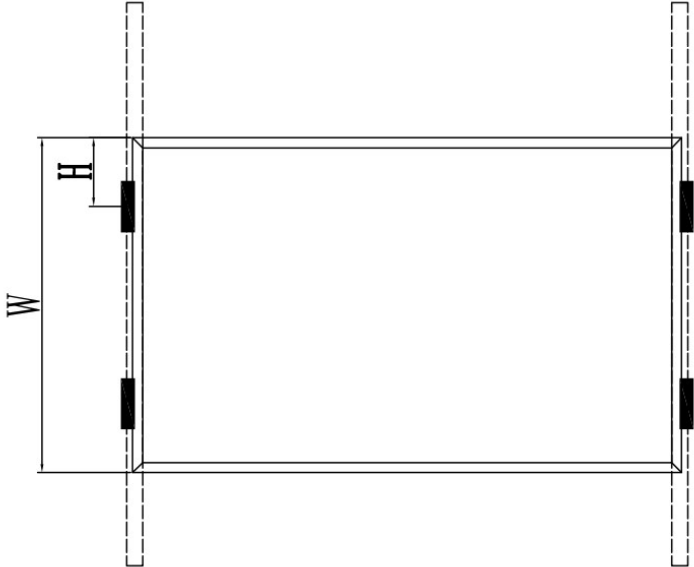
1. .L is the length of PV module. W is the wide of module. The black shadow is the area of installation.
2. The safety factor of mechanical load is 1.5 times.

	文件名称	单玻光伏组件安装说明书		
	文件编号	HTL-TR-I062 (V2.4)		
连云港神舟新能源有限公司	文件版本号	V2.4	页码	31 / 46

Method 3:


Installation of short side pressing block, design load ≤ 1600 Pa (front), 1600 Pa (back)

(Use 4 clamps- length of blocks ≥ 50 mm)

 <p style="text-align: center;">$0 < H < 1/4 W$</p>	NO.	L*W(mm)
	1	1324*992
	2	1640*826
	3	1640*992
	4	1650*992
	5	1665*992
	6	1665*1002
	7	1684*1002
	8	1755*1038
	9	1775*1052
	10	1924*1038
	11	1724*765
	12	1722*1134
	13	1909*1134

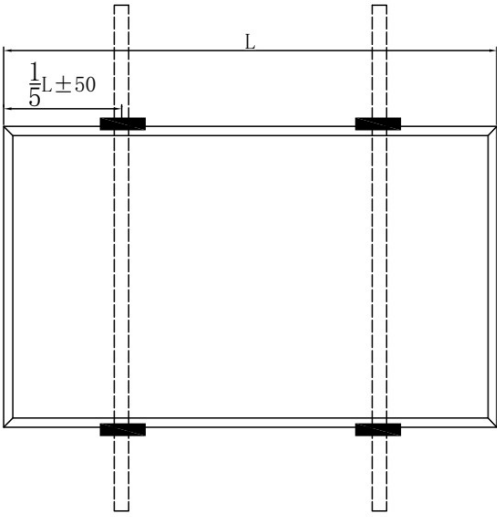
Notes:

1. L is the length of PV module. W is the wide of module. The black shadow is the area of installation.
2. The safety factor of mechanical load is 1.5 times.

	文件名称	单玻光伏组件安装说明书		
	文件编号	HTL-TR-I062 (V2.4)		
连云港神舟新能源有限公司	文件版本号	V2.4	页码	32 / 46

Method 4 (18X module, 72 and 78 board type) :

Installation of long side pressure block , design load ≤ 2400 Pa (front), 1600 Pa (back), (Use 4 clamps-length of blocks ≥ 50 mm)

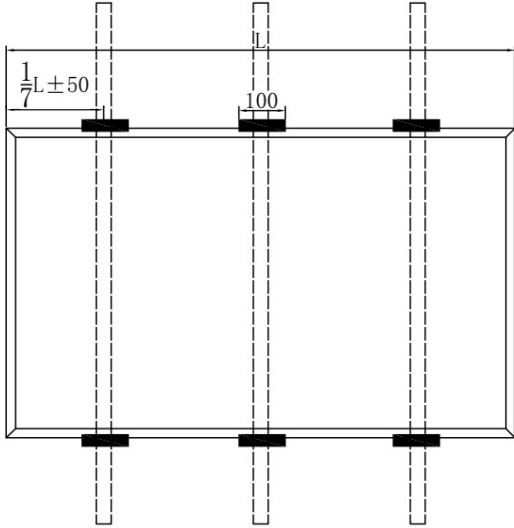
	1	2278*1134
	2	2465*1134

Notes:

1. L is the length of PV module. W is the wide of module. The black shadow is the area of installation.
2. The safety factor of mechanical load is 1.5 times.


Method5 (18X module, 72 and 78 board type) :

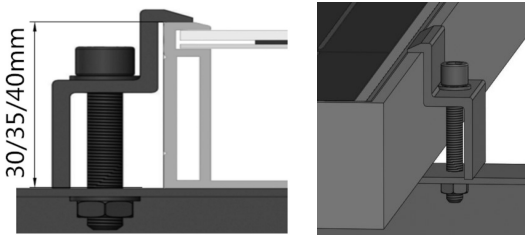
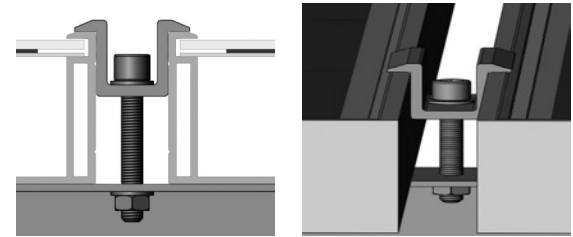
Installation of long side pressure block , design load ≤ 3600 Pa (front), 1600 Pa (back),(Use 6 clamps-length of blocks ≥ 50 mm)

	1	2278*1134
	2	2465*1134

Notes:

- 1.L is the length of PV module. W is the wide of module. The black shadow is the area of installation.
2. The safety factor of mechanical load is 1.5 times.

	文件名称	单玻光伏组件安装说明书		
	文件编号	HTL-TR-I062 (V2.4)		
连云港神舟新能源有限公司	文件版本号	V2.4	页码	33 / 46

End clamp installation(30/35/40mm optional)	Middle clamp installation
	
PV module installed with clamp fitting method.	

3.5 螺栓安装

每个组件的边框上都有 14×9mm 的安装孔，理想情况下可以优化组件负载能力，从而将组件固定到支撑结构上。

为了延长组件安装寿命，我们强烈建议使用防腐蚀（不锈钢）固定件固定组件。

使用 M8 螺栓和平垫圈，弹簧垫圈和螺母（如图 7 所示）将组件固定在每个固定位置，然后拧紧至 16-20N·m 的扭矩。

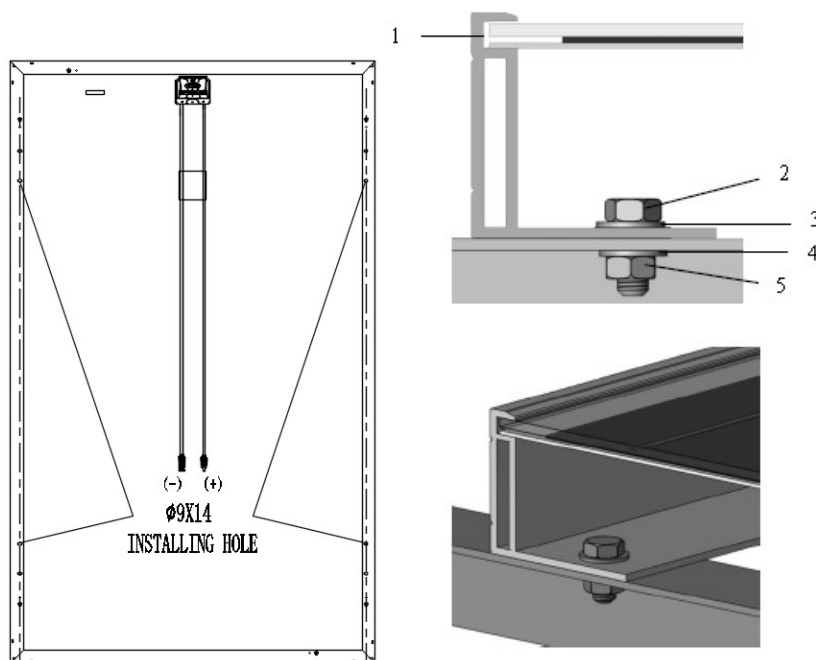

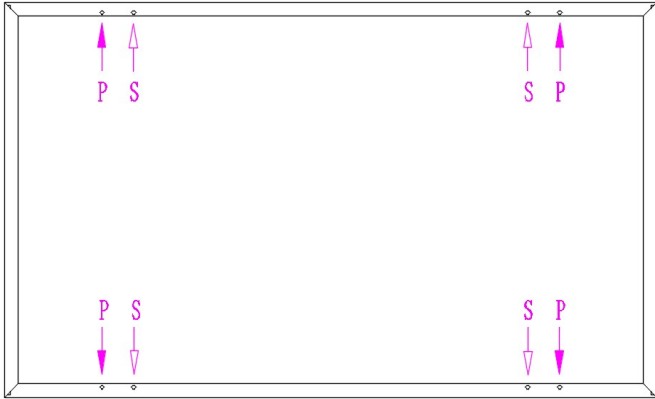


图 7 光伏组件的螺栓安装方式

- | | |
|-----------|------------|
| 1 铝边框 | 2 M8 不锈钢螺栓 |
| 3 平不锈钢垫圈 | 4 不锈钢弹簧垫圈 |
| 5 六角不锈钢螺母 | |

	文件名称	单玻光伏组件安装说明书		
	文件编号	HTL-TR-I062 (V2.4)		
连云港神舟新能源有限公司	文件版本号	V2.4	页码	34 / 46

螺栓安装方式			
NO.	L*W(mm)	设计载荷≤1600Pa（正面）、 1200Pa（背面）	设计载荷≤3600Pa（正面）、 2400Pa（背面）
		使用 4 个带有 S 或 P 的安装孔	使用 8 个带有 S 和 P 的安装孔
1	1324*992		
2	1640*826		
3	1640*992		
4	1650*992		
5	1665*992		
6	1665*1002		
7	1684*1002		
8	1755*1038		
9	1775*1052		
10	1924*1038		
11	1956*992		
12	1979*1002		
13	1987*992		
14	2008*1002		
15	2094*1038		
16	2115*1052		
17	1724*765		
18	1722*1134		
19	1909*1134		
20	2094*1134		
21	2278*1134		
22	2465*1134		

3.5 Installation of Bolts

The frame of each module has several $14 \times 9\text{mm}$ mounting holes. Ideally, the position of holes have ability to optimize the load distribution, to achieve great and strong module support structure.

In order to extend the life of module support, we advise to use anti-corrosion bolts or clamps (stainless

	文件名称	单玻光伏组件安装说明书		
	文件编号	HTL-TR-I062 (V2.4)		
连云港神舟新能源有限公司	文件版本号	V2.4	页码	35 / 46

steel) strongly.

Use M8 bolt and flat washer, spring washer and nut as shown in Figure 7 in each block. Tighten the bolts until the torque reaching 16-20 N·m.

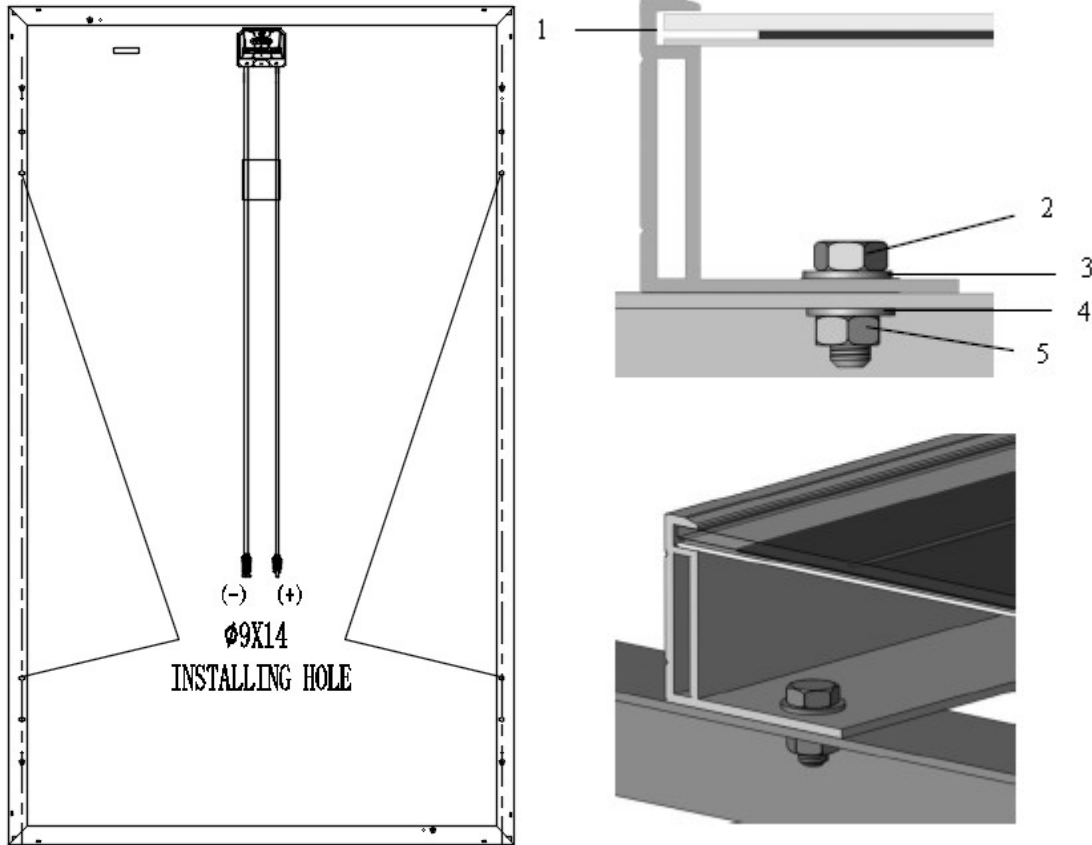

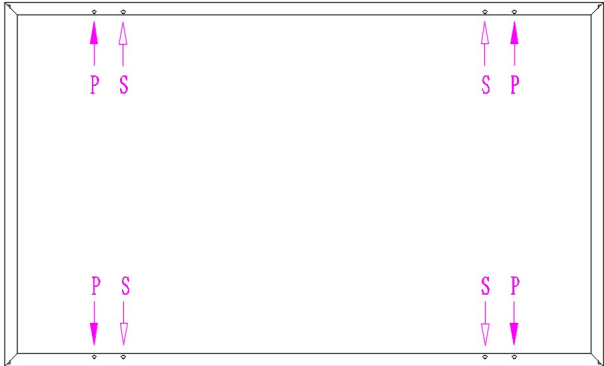


Figure 7. SPV module installed with Bolt fitting method

- 1 Aluminum Frame
- 2 M8 Stainless bolt
- 3 Flat Stainless Washer
- 4 Spring Stainless Washer
- 5 HEX Stainless Nut

	文件名称	单玻光伏组件安装说明书		
	文件编号	HTL-TR-I062 (V2.4)		
连云港神舟新能源有限公司	文件版本号	V2.4	页码	36 / 46

Installation of Bolts				
NO.	L*W(mm)	Design Load≤1600Pa (front), 1200 Pa (back)	Design Load≤3600Pa (front), 2400 Pa (back)	
		Use 4 installation holes with S or P holes	Use 8 installation holes with S and P holes	
1	1324*992			
2	1640*826			
3	1640*992			
4	1650*992			
5	1665*992			
6	1665*1002			
7	1684*1002			
8	1755*1038			
9	1775*1052			
10	1924*1038			
11	1956*992			
12	1979*1002			
13	1987*992			
14	2008*1002			
15	2094*1038			
16	2115*1052			
17	1724*765			
18	1722*1134			
19	1909*1134			
20	2094*1134			
21	2278*1134			
22	2465*1134			

3.6 单轴跟踪系统安装

有的型号组件边框上有用于单轴跟踪系统安装的安装孔，通过这些安装孔可以很好地将组件固定到支撑结构上以优化其负载承受能力。通过组件背面边框上的安装孔，使用螺栓把组件固定在支架上，安装细节下图所示。使用 M6 螺栓、平垫圈、弹簧垫圈和螺母在每个固定位置固定组件，并拧紧至 16-20 N.m (140-180lbf.in) 的扭矩。与单轴跟踪系统连接的组件的所有部位应采用最小厚度为 1.5mm 且外径为 16-20mm (0.63-0.79 英寸) 的扁平不锈钢垫圈。此安装方式的正面最大设计载荷为 1200Pa，背面设计载荷为 1200Pa，安全系数为 1.5 倍。组件有效载荷=设计载荷*机械载荷安全

	文件名称	单玻光伏组件安装说明书		
	文件编号	HTL-TR-I062 (V2.4)		
连云港神舟新能源有限公司	文件版本号	V2.4	页码	37 / 46

因子倍数（1.5）。

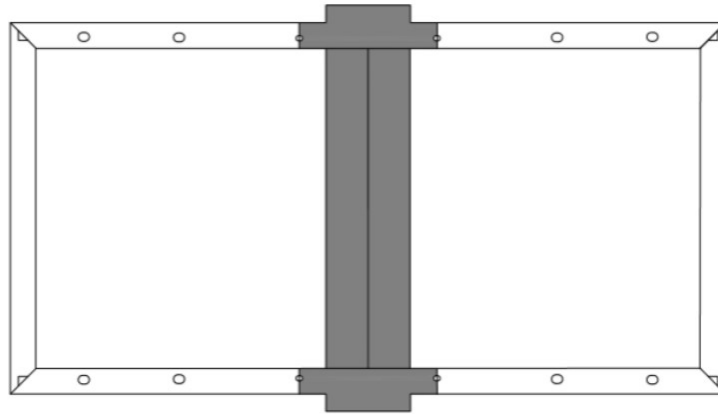


图 8 单轴跟踪系统安装图示

3.6 Installation of Single-axis Tracking System

In some special type of modules, there are installation holes on the frame, which use for installation of single-axis tracking system. These installation holes, including normal holes and single-axis tracking holes, is good for press distribution and achieve strong support structure. With help of installation holes on the aluminum frame of the module, bolts can be used to connect module and support. The detail of installation is showed in follow figure. Use M6 bolt and a flat washer, spring washer and nut for connection between modules and supports. Tighten the bolts until the torque reach 16-20N.m (0.63-0.79 inches). The modules connected with single-axis tracking system needs special stainless steel washers with a minimum thickness of 1.5mm and an external diameter of 16-20mm (0.63-0.79 inches). In these install method, the maximum design load of the front is 1200pa, the design load of the back is 1200pa, and the safety factor is 1.5 times. Component payload = design load * mechanical load safety factor multiple (1.5).

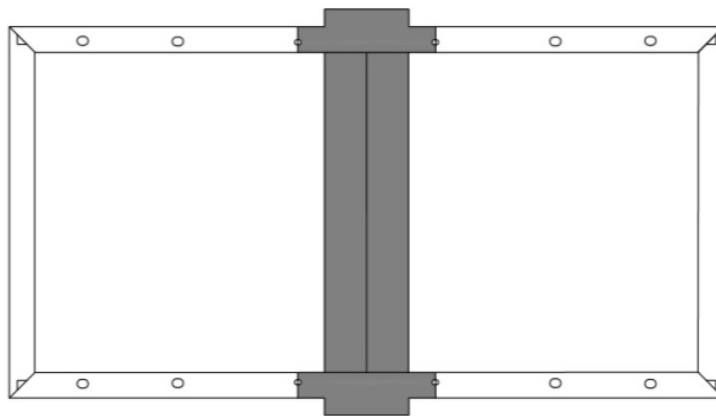



Figure 8 Installation diagram of module with single-axis tracking system

	文件名称	单玻光伏组件安装说明书		
	文件编号	HTL-TR-I062 (V2.4)		
连云港神舟新能源有限公司	文件版本号	V2.4	页码	38 / 46

4 电气连接

4.1 电气连接注意事项

4.1.1 接线前请仔细阅读该光伏系统电气布线图纸，所有接线应由合格的安装人员按照当地法规和程序进行。系统的最高电压必须低于最高认证电压以及安装中系统中的变频器及其他电气设备的最高输入电压。

4.1.2 组件和接线箱的连接：使用直流电缆将组件串与接线箱相连。电缆的横截面积和连接器容量必须满足系统的短路电流。用于单个组件的电缆线横截面积推荐为 4mm^2 ，保险丝电流大于或等于 20A（型号为 18X 系列的组件及双面组件需 $\geq 25\text{A}$ ），连接器的额定电流大于 20A（型号为 18X 系列的组件及双面组件需 $\geq 25\text{A}$ ），否则电缆线和连接器会因为大电流而过热。请注意电缆承受温度的上限为 90°C ，连接器承受温度的上限为 125°C 。

4.1.3 组件铝边框和组件支架必须接地，如图 9 所示，每个组件均有接地孔，并在边框上做标记（建议每个组件的串联/并联必须接地一次）。接地螺栓安装方式如图 10 所示。接地线和边框将通过预留接地孔可靠接地，通过安装螺栓 M5 \times 10~15 匹配平垫圈、弹簧垫圈和螺母。组件和接地线应通过接线头完美连接。可安装负极接地逆变器，防止 PID 现象。

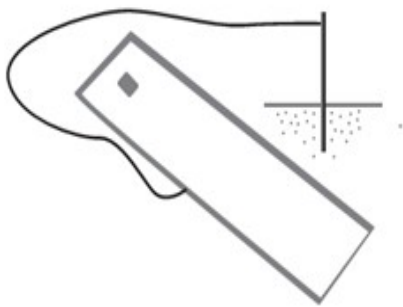


图 9 组件接地图

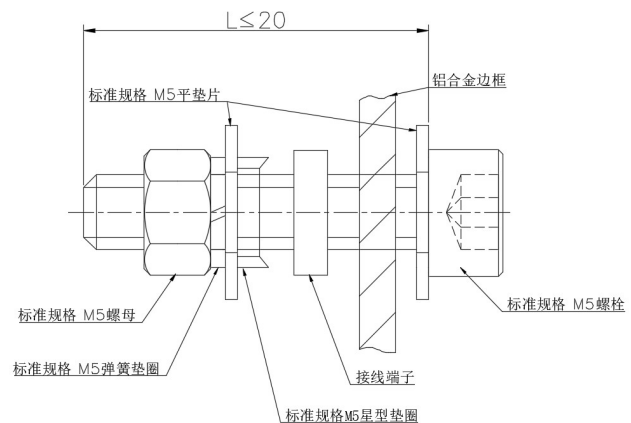



图 10 接地螺栓安装示意图

4.1.4 如果使用常见的接地硬件(螺母、螺栓、星形垫圈、开环锁紧垫圈、平板垫圈等)用来连接接地/连接装置，安装时必须按照接地配件制造商的说明进行。

4.1.5 常见的接地连接硬件项目如螺母、螺栓、星形垫圈、锁紧垫圈等还没被评估电导率的硬件，只能用于维护机械连接，并保持适当的接地装置的导电率。这些硬件随组件一起提供并按要求通过

	文件名称	单玻光伏组件安装说明书		
	文件编号	HTL-TR-I062 (V2.4)		
连云港神舟新能源有限公司	文件版本号	V2.4	页码	39 / 46

UL 1703 中的评估，可用于根据组件安装说明进行接地连接。

4.1.6 电气连接应符合当地电气法规，组件系统电气连接不允许出现“Y”型电气连接方式。

4.1.7 组件中装有旁路二极管（额定电压 45V，额定电流 25A）如出现不正确的安装，二极管、电缆和接线盒可能会受到破坏。

4.1.8 组件从包装内取出后，在不立即安装的情况下需保护好连接器，以免因风或雨造成损坏。禁止在连接器上使用润滑剂，连接器不得被太阳暴晒。

4.1.9 切勿将防水胶环从接线盒或连接器上拆下。

4.1.10 安装现场严禁使用柴油取暖。柴油和其他石油产品燃烧产生的气体可能损坏连接器。

4.1.11 电缆的最小弯曲半径应为 43mm（1.69 英寸）。


4 Electrical Connection

4.1 Precautions for Electrical Connection

4.1.1 Please read the electrical wiring drawings carefully before wiring. The wiring should accord to local law and program and be operated by certificated electricians. The maximum voltage of the system must be lower than the maximum certified voltage and the maximum input voltage of the inverter and other electrical devices installed in the system.

4.1.2 The connection between module and junction box: the module is connected with junction box by the dc cable. The cross-sectional area of cable and the connector capacity must be satisfied with the system's short circuit current. The cable's cross-sectional area for a single module is recommended to be 4mm². The fuse current and the rated current of the connector should be higher than 20A(18X series module s and double-sided modules should be $\geq 25A$). Otherwise, the cables and connectors will overheat due to high current. Please note that the highest temperature of cable is 90 °C, and the highest temperature of connector is 125 °C.

4.1.3 The aluminum frame and support of the module must be grounded, as shown in Figure 9. Each module has a grounding hole and is marked on the frame (it is recommended that the series / parallel connection of each module must be grounded once). The installation method of grounding bolt is shown in FIG. 10. The grounding wire and frame can be reliably grounded by the prepared grounding hole. And the flat washers, spring washers and nuts are matched by installing bolts M5 × 10 ~ 15. The modules and the earth wire shall be perfectly connected by connecting plugs. Negative grounding inverter can be installed to

	文件名称	单玻光伏组件安装说明书		
	文件编号	HTL-TR-I062 (V2.4)		
连云港神舟新能源有限公司	文件版本号	V2.4	页码	40 / 46

prevent PID phenomenon.

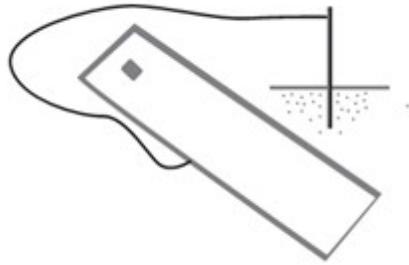


Figure 9 Module grounding circuit

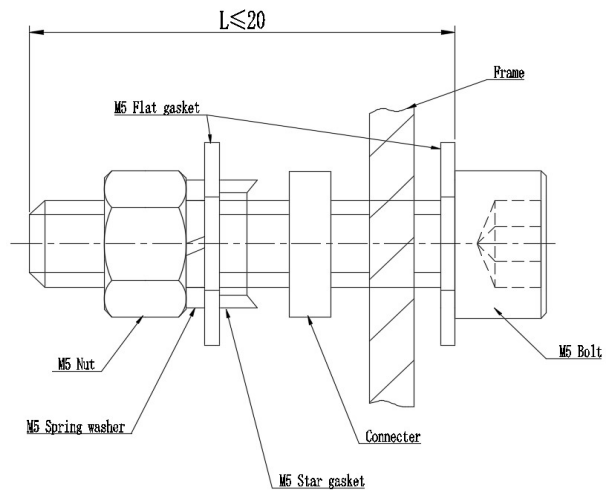


Figure 10 Installation diagram of grounding bolt

4.1.4 Common hardware parts, such as nuts, bolts, star washers, lock washers, flat washers, are used for grounding/connecting. The installation of such hardware parts should comply with instructions of manufacturers.

4.1.5 The common grounding parts, such as nuts, bolts, star washers, lock washers, which have not been evaluated for electrical conductivity, are only to use for mechanical connection. And the grounding parts of the module should keep suitable conductivity. These grounding parts, which supply the evaluation of UL 1703 as the same as modules, can use for module's installation according to installation instruction.

4.1.6 The electrical connection shall conform to local electrical laws and regulations. Avoid "Y" type electrical connection mode in module system electrical connection.


4.1.7 Modules are equipped with bypass diodes (rated voltage 45V, rated current 25A). The improper installation may damage diodes, cables or junction box.

4.1.8 If the modules unpack without installation immediately, please protect module connectors in order to avoid damage due to wind or rain. Avoid lubricant on module's connectors. The connectors shall not be exposed to the sun

4.1.9 Avoid removing the waterproof rubber rings out from the junction box or connectors.

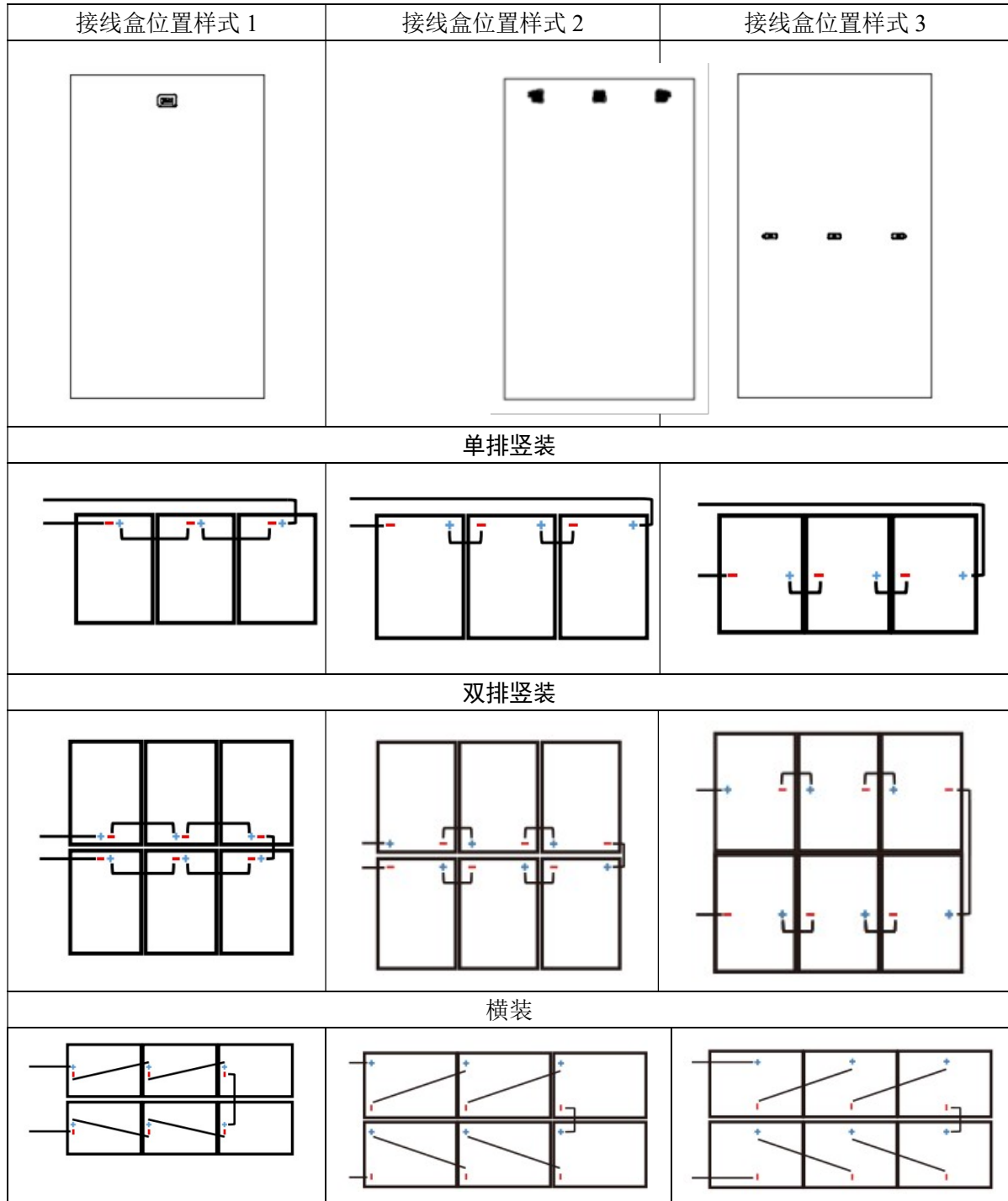
4.1.10 Avoid using diesel oil to keep warm in installation site, because the gas generated by diesel oil or other petroleum products may destroy module's connector.


4.1.11 The minimum bending radius cables should be 43mm (1.69in).

	文件名称	单玻光伏组件安装说明书		
	文件编号	HTL-TR-I062 (V2.4)		
连云港神舟新能源有限公司	文件版本号	V2.4	页码	41 / 46

4.2 组件接线

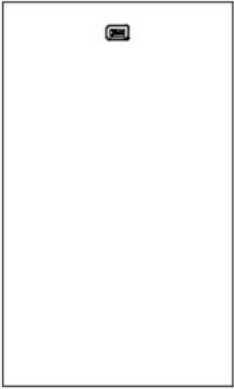

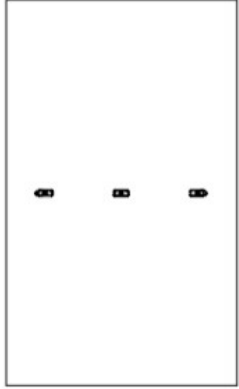
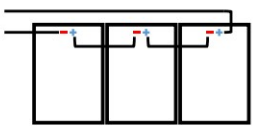
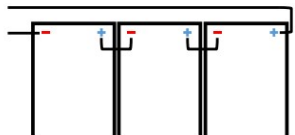
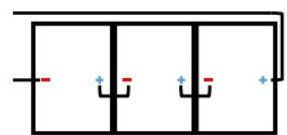
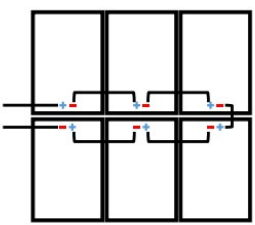
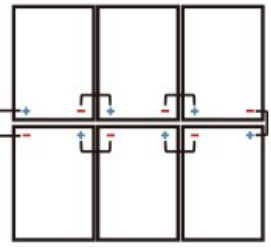
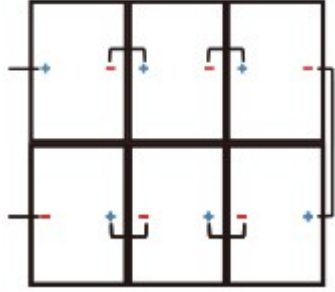
4.2.1 竖向单排组件电缆可以短一些，竖向双排会在上下组件连接时增加一根跳线，在前期估算时不要遗漏。一般的，60板型一体式接线盒标准线长0.9m，72板型一体式接线盒标准线长1.1m，分体式接线盒标准线长正负极分别为0.2m和0.3m（其他大尺寸板型和特殊板型组件线长以对应的产品参数手册为准）。


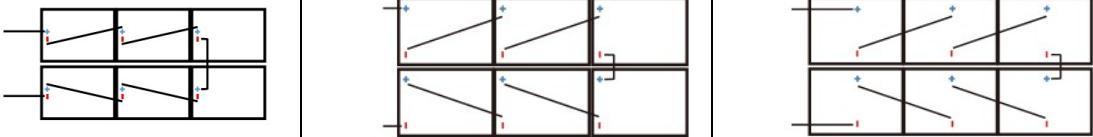


	文件名称	单玻光伏组件安装说明书		
	文件编号	HTL-TR-I062 (V2.4)		
连云港神舟新能源有限公司	文件版本号	V2.4	页码	42 / 46

4.2 Wiring and Connections

4.2.1 When the long side of module is perpendicular to the ground, if there is only a row of modules, the cables which connect adjacent modules can be short. If there are two row modules, which long sides are perpendicular to ground, it needs a special jump cable to connect up and down modules. Please do not ignore the jump cable during 2 row modules system design. Generally, the standard wire length of 60 plate type integrated junction box is 0.9m. The standard wire length of 72 plate type junction box is 1.1m. If the module has separated junction boxes, the standard wire length of each separated junction box is 0.2m (positive) and 0.3m (negative) respectively. The wire length of other large-size plate and special plate components shall be subject to the corresponding product parameter manual.

Junction box position style 1	Junction box position style 2	Junction box position style 3
		
Single row installation with long side of modules perpendicular to the ground		
		
Two row module installation		
		
Two row module installation with long side parallel to the ground		

	文件名称	单玻光伏组件安装说明书		
	文件编号	HTL-TR-I062 (V2.4)		
连云港神舟新能源有限公司	文件版本号	V2.4	页码	43 / 46
				

5 保养维护

组件需要定期进行检查和维护，包括组件的外观、所有的电气连接，确保没有开路，连接良好。

- 检查每个组件的开路电压：
- 用不透明的材料完全覆盖在组件受光的表面上。暴露在阳光下的组件会产生危险的电压。
- 断开组件两端的导线。
- 取掉组件上的不透明材料，检查并测量终端的开路电压。
- 如果测量的电压减少 1/4 以上，可能是旁路二极管损坏，请测试旁路二极管性能。
- 推荐下列维护措施以确保组件的最佳性能：

检查组件是否存在外观缺陷：组件表面是否有破损、异常，组件是否被物品等遮挡，组件与支架之间的固定是否存在松动，发现异常后需联系有资质或经验的维护人员进行调整或修复。


•尽可能每年清洁一次组件，可根据当地具体情况而定。组件表面出现脏污时，会减少发电量。清洁时，可以使用软海绵或抹布沾水清洁组件的玻璃表面。可使用温和的，不加研磨剂的清洗剂去除顽垢。严禁使用具有腐蚀性的化学清洁剂。为减少电击或灼伤，建议在清晨或傍晚进行组件清洁工作。

•每 6 个月进行机械和电气检查，确保组件接头清洁及连接可靠、确保组件电气连接良好，无腐蚀现象。

- 如有任何疑问，请具有资质的人员进行检查。
- 遵守系统使用的所有部件，如支架、充电整流器、逆变器、电池等的维护说明。
- 交叉轮式垃圾箱的意义：



不要将电器作为未分类的城市垃圾处理，使用单独的收集设施。有关可用的收集系统的信息，请与当地政府联系。如果电器是在垃圾填埋场或垃圾场处理的，有害物质会渗入地下水，进入食物链，损害你的健康。当用新电器替换旧电器时，零售商在法律上有义务收回旧电器进行处置，至少

	文件名称	单玻光伏组件安装说明书		
	文件编号	HTL-TR-I062 (V2.4)		
连云港神舟新能源有限公司	文件版本号	V2.4	页码	44 / 46

是免费的。

5 Maintenance

The modules need to be inspected and maintained regularly, including visual inspection and all electrical connections to ensure that there is stable connection without any broken.

- Check the open circuit voltage of each module:
- Cover the front surface of modules with an opaque material. There is hazard voltage if modules exposed in light illumination.
- Disconnect the wires from both sides of the module.
- Remove the non-transparent material off the modules; check and measure the open circuit voltage of the modules.
- If the measured voltage is reduced by 1/4, it supposed to be bypass diode damaged. Please test the bypass diode performance.
- It's recommend that adopt the following maintenance to ensure the modules maintain the best performance:


Check whether the modules have any appearance defect: such as surface damage, abnormal or shadow. Make sure that the module support system is stable without any loose part. If finding any abnormal situation, please contact professionals to adjust or repair.

- Clean modules at least one time each year, depending on local conditions. If the surface of the module becomes dirty, the power generation of the modules reduces. In this situation, you can use soft sponge or water to clean the surface glass of the module. Mild, non-abrasive chemical cleaners can be used to help washing modules. Avoid using any corrosion chemical cleaners. In order to reduce electric shock or burns, it is recommended to clean modules in the morning or evening.

- Check mechanical and electrical property of modules every six months to ensure the modules' connectors clean and reliable. And ensure good electrical connection and no corrosion.

- If you have any questions, please contact with professionals and arrange further check.
- Please note that all maintenance instructions, such as brackets, charging rectifier, inverters and batteries, should be complied.

- Meaning of crossed –out wheeled dustbin:

	文件名称	单玻光伏组件安装说明书		
	文件编号	HTL-TR-I062 (V2.4)		
连云港神舟新能源有限公司	文件版本号	V2.4	页码	45 / 46



Do not dispose of electrical appliances as unsorted municipal waste, use separate collection facilities.

Contact your local government for information regarding the collection systems available.

If electrical appliances are disposed of in landfills or dumps, hazardous substances can leak into the groundwater and get into the food chain, damaging your health and well-being.

When replacing old appliances with new ones, the retailer is legally obligated to take back your old appliance for disposals.

6 免责声明

由于本手册的使用及组件安装、操作、使用和维护条件超出了我们的控制范围，我们不承担任何因安装、操作、使用或维护中所引起的损失、破坏或费用责任。

我们不承担任何由于使用组件产品可能导致的侵犯专利和第三方权利的责任。客户并不因使用我们产品而获得任何专利或者专利权利的使用授权，无论是明示的或隐含的。


本手册的信息基于我们的被认为是可靠的知识和经验，但是包括但不限于如上的产品规格的这些信息和建议并不构成任何保证条款，无论明示的或隐含的。我们保留修改手册、PV 产品、规格或产品信息的权利，无需提前通知。

6 Disclaimer

Because the use of the manual and the conditions or methods of installation, operation, use and maintenance of photovoltaic (PV) product are beyond the control of Lianyungang Shenzhou New Energy Co.,Ltd. We do not accept responsibility and expressly disclaims liability for loss, damage, or expense arising out of or in any way connected with such installation, operation, use or maintenance.

No responsibility is assumed by Lianyungang Shenzhou New Energy Co.,Ltd. for any infringement of patents or other rights of third parties, which may result from use of the PV product. NO license is granted by implication or otherwise under any patent or patent rights.

The information in this manual is based on our knowledge and experience and is believed to be reliable, but such information including product specification (without limitations) and suggestions do not constitute a warranty, expresses or implied. We reserve the right to change the manual, the PV produce, the

	文件名称	单玻光伏组件安装说明书		
	文件编号	HTL-TR-I062 (V2.4)		
连云港神舟新能源有限公司	文件版本号	V2.4	页码	46 / 46

specifications, or product information sheets without prior notice.